

Two concentric axial members are grounded at node A and are connected to a rigid connector at node B. Member (1) is made of steel and member (2) is made of aluminum. The temperature of the assembly is increased by 40 °C (both (1) and (2) are heated uniformly).

- (a) What are the stresses in (1) and (2)?
 (b) What is the displacement of node B?

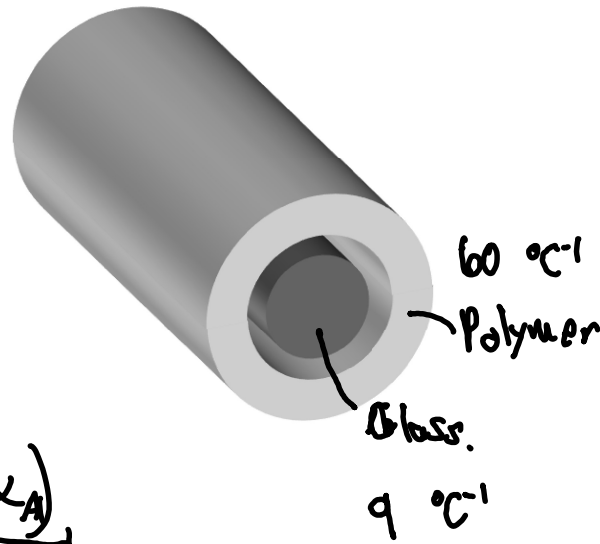
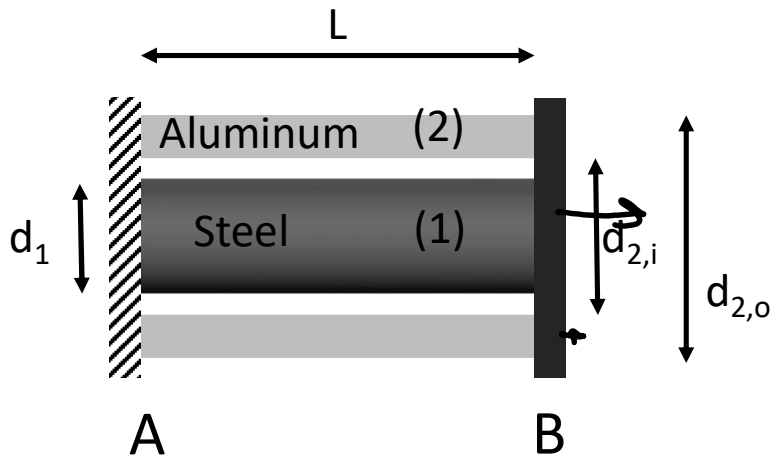

Variable	Value
L	1 m
d_1	0.08 m
$d_{2,i}$	0.10 m
$d_{2,o}$	0.12 m
α_{Steel}	$15 \times 10^{-6} \text{ } ^\circ\text{C}^{-1}$
α_{Al}	$24 \times 10^{-6} \text{ } ^\circ\text{C}^{-1}$
E_{Steel}	240 GPa
E_{Al}	60 GPa

Lecture 9 Review

$$e_1 = \underbrace{u_c \cos \theta_1}_{\text{axial}} + \underbrace{v_c \sin \theta_1}_{\text{shear}} \quad \theta_1 = 210^\circ.$$

In our general equation for the relationship between the elongation of a member and the displacement of a node in the x and y directions, what angle is used in member (1)?

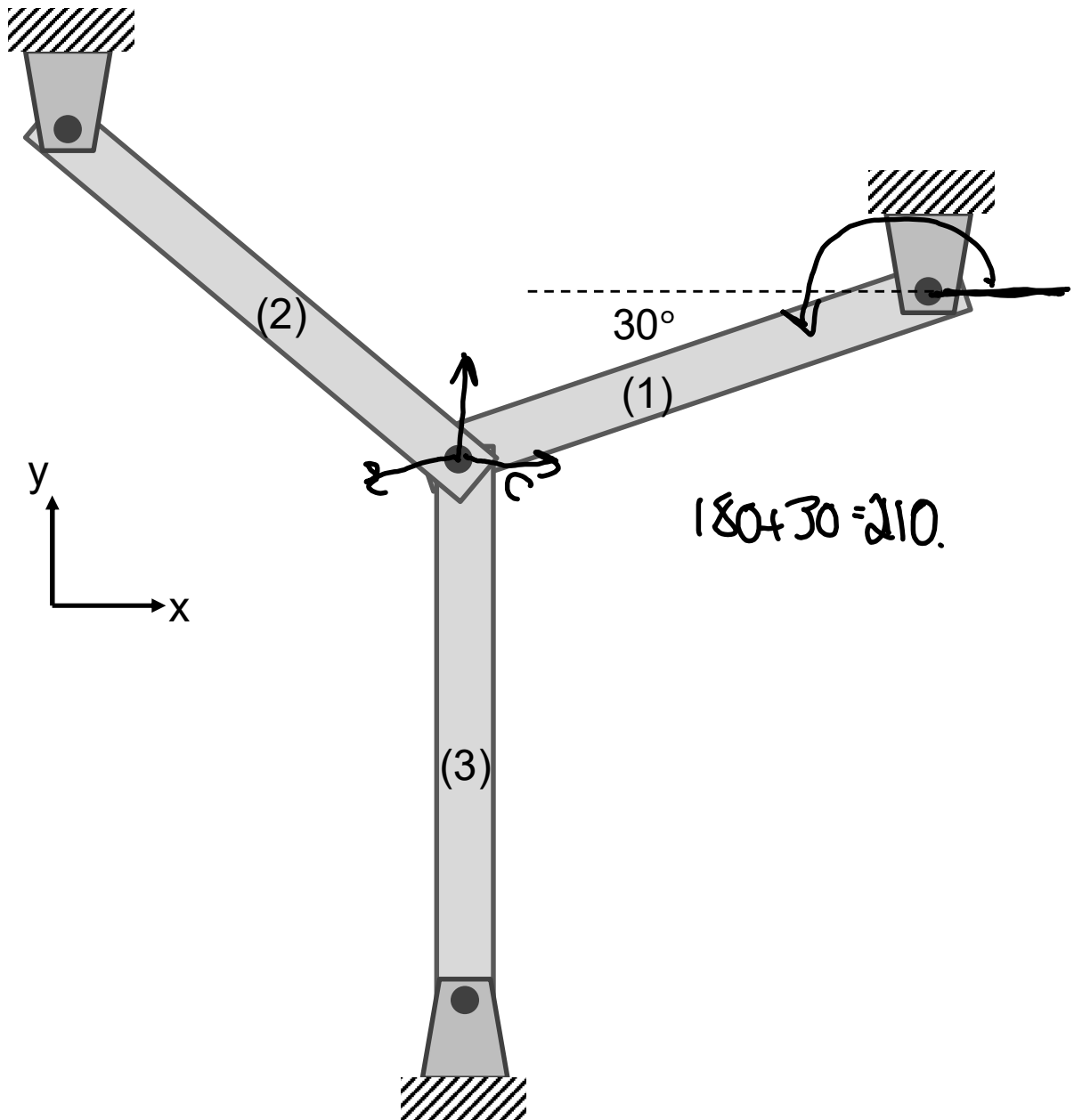

8. Stress analysis of members in torsion

Objectives:

To study the stresses developed in circular cross-sectioned shafts experiencing torsion loading.

Background:

- Shear strain:

$$\gamma = \frac{\pi}{2} - \theta^* \approx \frac{\delta_s}{L_s}$$

- Hooke's Law of shear

$$\tau = G\gamma$$

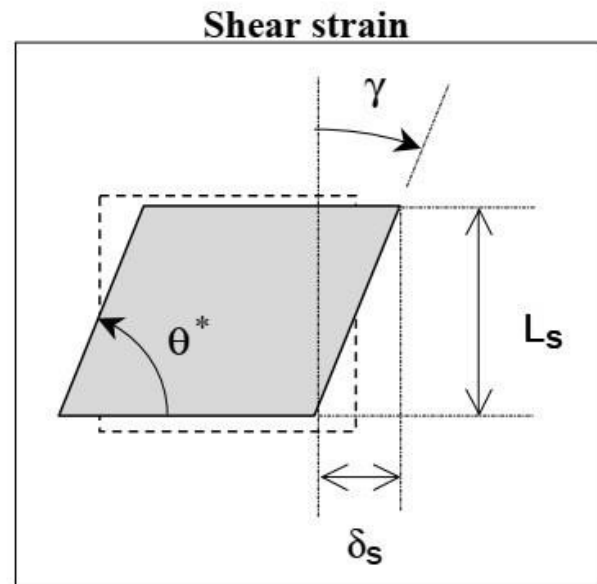

Lecture topics:

- a) Geometry of deformation – shear strains
- b) Shear stress and strain due to torsion in circular members
- c) Statically indeterminate shafts with externally-applied torques

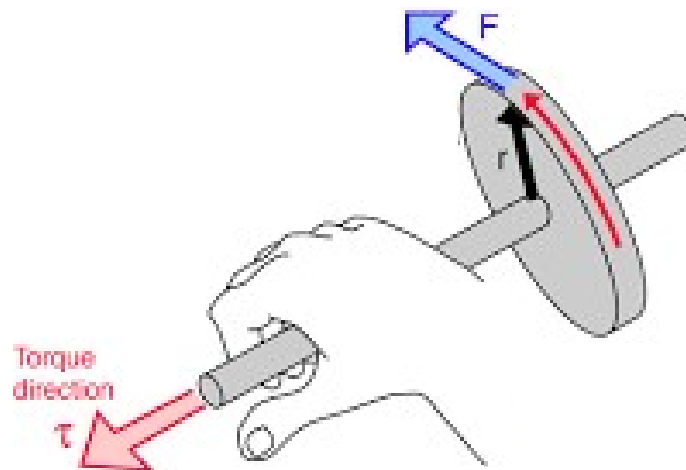

Examples of members in torsion

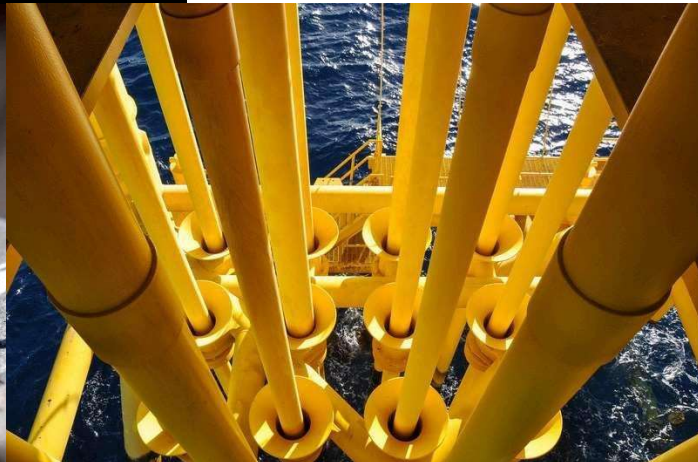
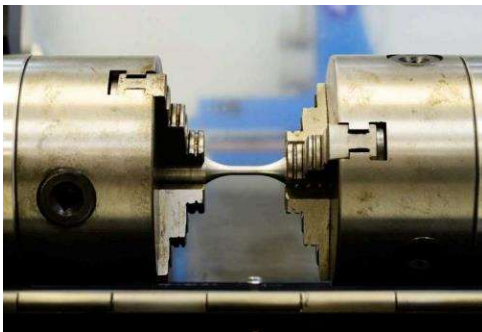

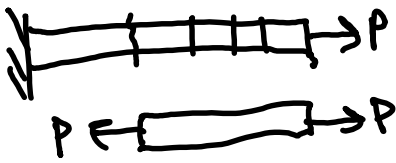

Lecture Notes

Sign convention for torque

The sign of a torque T acting on a cut face of a shaft is determined by the right hand rule. Curling the fingers of your right hand in the direction of the torque has the thumb of that hand pointing in the direction of the torque: if the direction of the torque is pointing outward (inward) on a face of the shaft, then that torque is positive (negative).

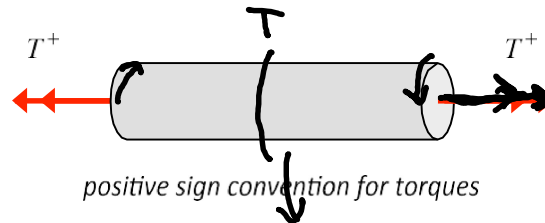

Angle of twist

A torque T being applied a cross section of the shaft will rotate a cross section of the shaft through an angle ϕ (known as the “angle of twist”); see, for example, point A on the outer surface moving to point A' as a result of an applied torque. The angle of twist is assumed to be constant across a given cross section. Please note that the angle of twist on a positive x-face of the shaft and torques are governed by the same right-hand-rule sign convention; consequently, a positive torque acting on a section of the shaft produces a positive angle of twist in that section of the shaft.

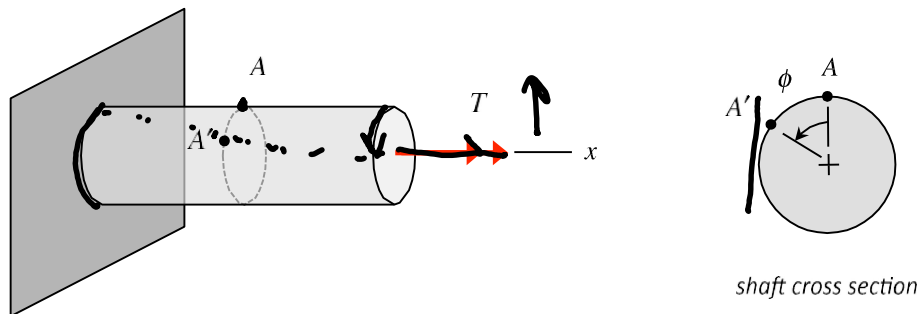

Assumptions:

- Only circular cross section shafts will be considered.
- Cross sections remain perpendicular to shaft axis after deformation (this is not a valid assumption, in general, for non-circular cross section bars).
- Radial lines remain radial (i.e. every point on a cross section rotates by the same amount).
- Shaft axis remains straight.

a) Geometry of deformation – shear strains

Resultant torque T (about x-axis) applied to a face perpendicular to x-axis:

$$\frac{F}{A} = \tau$$

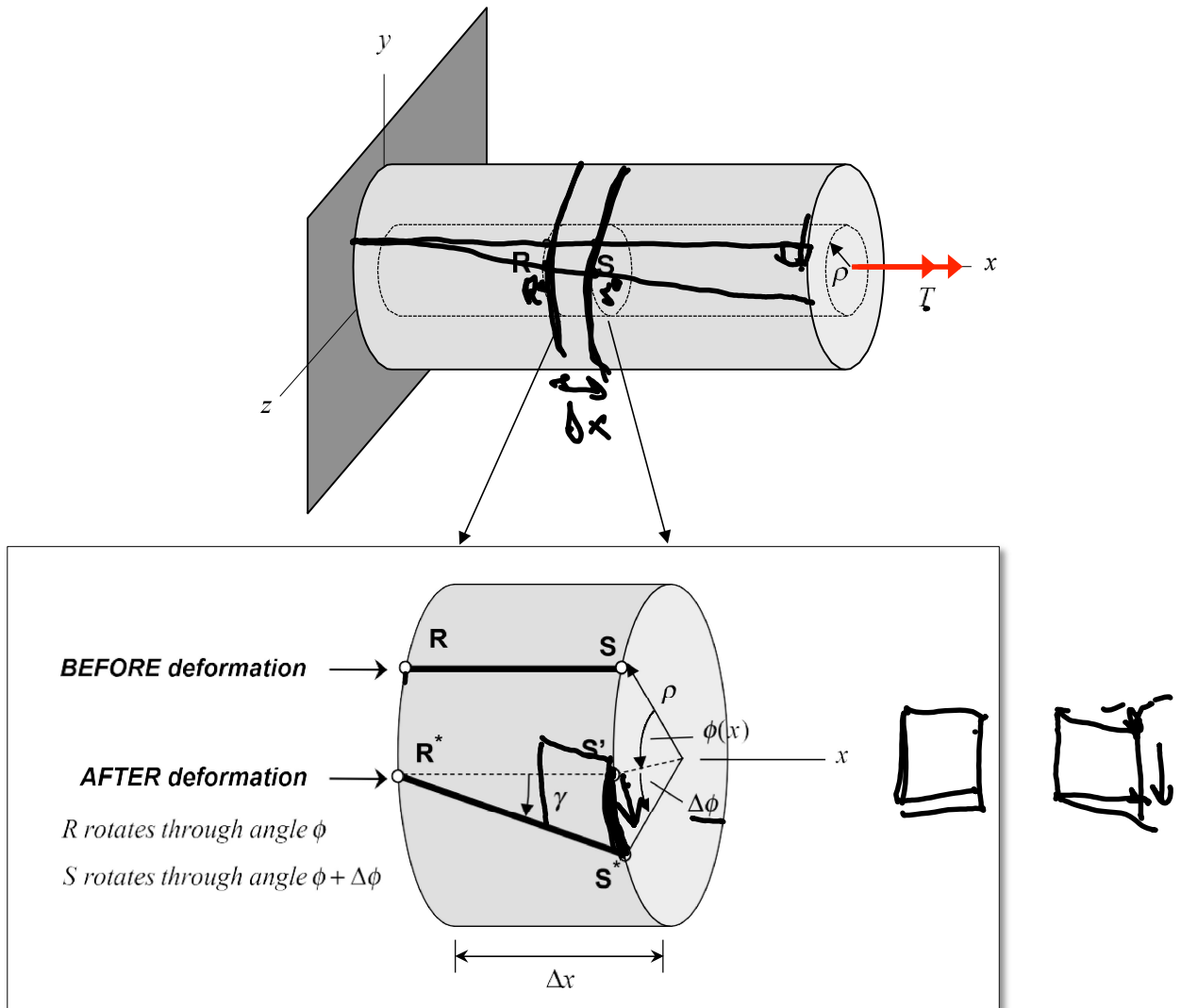

Consider two points R and S on the surface of an annular section of the shaft of radius ρ and length Δx , where R is at a location x and S is at a location $x + \Delta x$. As a result of the applied torque, the shaft experiences a rotational deformation, with R rotating through an angle of $\phi(x)$ to position R^* , and S rotating through an angle of $\phi(x) + \Delta\phi$ to position S^* , as shown in the figure.

From our earlier definition of shear strain, the shear strain is given by the angle γ , where from the above figure we have:

$$\gamma = \lim_{\Delta x \rightarrow 0} \left(\frac{S'S^*}{\Delta x} \right)$$

From the figure above, we see that $S'S^* = \rho \Delta\phi$. Therefore,

$$\underline{\gamma} = \lim_{\Delta x \rightarrow 0} \left(\frac{\rho \Delta \phi}{\Delta x} \right) = \rho \lim_{\Delta x \rightarrow 0} \left(\frac{\Delta \phi}{\Delta x} \right) = \rho \frac{d\phi}{dx} \quad (1)$$

b) Shear stress due to torsion in circular members

Here we consider a resultant torque T (about x -axis) applied to right-end face perpendicular to x -axis:

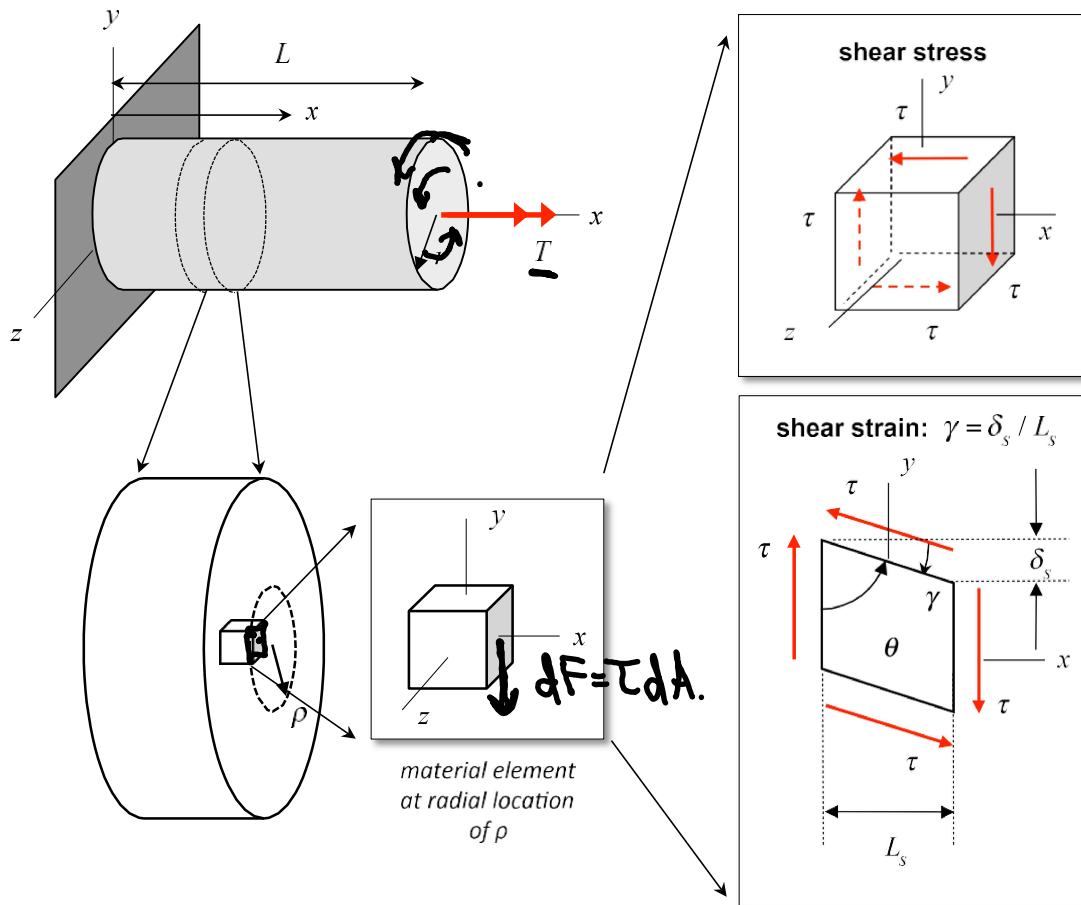

A differential stress cube at a radius of ρ at some location in the shaft is shown above. As a result of the applied torque, a state of pure shear is developed in the stress cube. The resultant force on the face of the stress cube at the cut is given by $dF = \tau dA$, where dA is a differential area on the shaft cross-section, and τ is the shear stress on the cube. The torque on the cut face of the shaft due to this differential force is $\underline{dT} = \underline{\rho} dF = \rho \tau dA$.

Hooke's Law

For a linearly elastic material, we have:

$$\tau = G\gamma \quad (2)$$

Shear stress-torque relation

From this we have following relation between the applied torque and the developed shear stress:

$$T = \int_A \rho \tau dA = \int_A \rho G \gamma dA \quad T = \int_A dT dA. \quad (3)$$

Substituting (1) into (3) gives:

$$T = \int_A \rho^2 G \frac{d\phi}{dx} dA \quad (4)$$

If the shear modulus G is constant across the cross section, the above reduces to:

$$T = G \frac{d\phi}{dx} \int_A \rho^2 dA \Rightarrow \frac{d\phi}{dx} = \frac{T}{G \int_A \rho^2 dA} = \frac{T}{GI_P} \quad (5)$$

where:

$$I_P = \int_A \rho^2 dA = \text{"polar area moment" of the shaft cross section}$$
$$= \int_A \rho^2 (\rho d\rho d\theta) = \int_A \rho^3 d\rho d\theta \quad \leftarrow$$

Combining equations (1), (2) and (5) gives the final result relating shear stress to applied torque:

$$\tau = G\gamma = G\rho \frac{d\phi}{dx} = G\rho \left(\frac{T}{GI_P} \right) = \frac{T\rho}{I_P} \quad (6)$$

Torque-angle of twist relation

Integrating equation (5) over the length of the shaft gives:

$$\Delta\phi = \phi(L) - \phi(0) = \int_0^L \frac{T}{GI_P} dx \quad (7)$$

If the torque T , the shear modulus G and polar area moment I_P do not vary along the shaft's length, then equation (7) becomes:

$$\Delta\phi = \frac{TL}{GI_P} \quad (7a)$$

Discussion:

- a) Equation (6) shows that the shear stress in a circular shaft due to an applied T varies linearly with radial distance ρ from the center of the shaft.
- b) The maximum shear stress in the shaft occurs on the outer perimeter of the shaft (for $\rho = r$) and is given by:

$$\underline{\tau_{max}} = \frac{Tr}{I_P}$$

- c) For a *solid* shaft with outer radius r_o , the polar area moment of the shaft becomes:

$$(I_P)_s = \int_0^{2\pi} \left(\int_0^{r_o} \rho^3 d\rho \right) d\theta = \frac{\pi r_o^4}{2}$$

- d) For a *tubular* shaft with inner radius r_i and outer radius r_o , the polar area moment of the shaft becomes:

$$(I_P)_t = \int_0^{2\pi} \left(\int_{r_i}^{r_o} \rho^3 d\rho \right) d\theta = \frac{\pi}{2} (r_o^4 - r_i^4)$$

- e) Note that for the same outer radius r_o , the polar area moment for the solid shaft is greater than that of the tubular shaft, $(I_P)_s > (I_P)_t$. Since $\tau_{max} = Tr_o / I_P$, the maximum shear stress in a solid shaft is less than that of the tubular shaft, $\tau_{max,s} < \tau_{max,t}$. If a solid shaft can carry a larger torque T than that of a tubular shaft without exceeding a desired maximum shear stress, why would a designer choose a tubular shaft over a solid shaft??

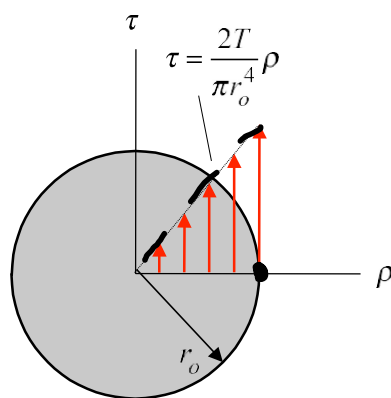

shear stress distribution
in solid shaft

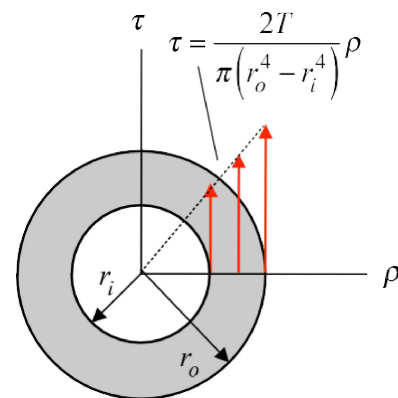

shear stress distribution
in tubular shaft

Strength/Weight Ratio

$$\left[\tau = \frac{T\rho}{I_p} \right] \quad T = \frac{\tau_U I_p}{\rho} = \left(\frac{\pi}{2} \right) \frac{\tau_U (r_o^4 - r_i^4)}{r_o}$$

$$\underline{\text{Weight}} = \pi (r_o^2 - r_i^2) L$$

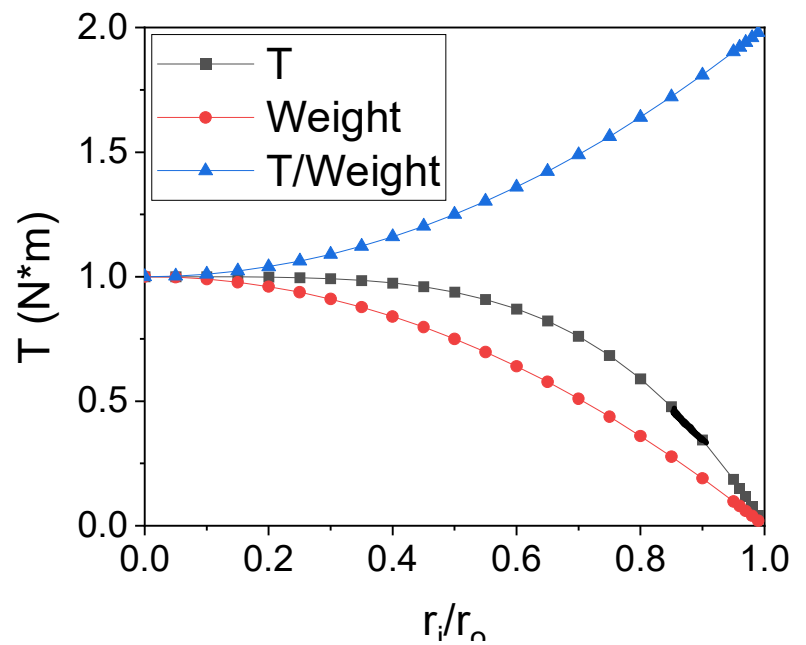
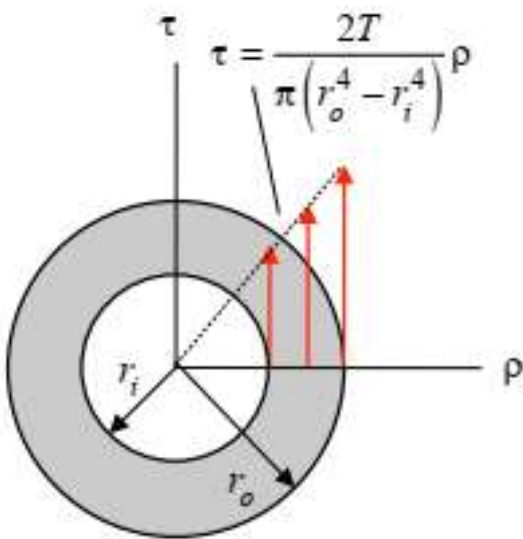

States of stress in shaft

Consider the shaft shown below loaded with a torque T along the x -axis. Points on a given cross section of the shaft will experience a state of shear stress given by:

$$\tau = \frac{T\rho}{I_P}$$

The direction of this component of shear stress will depend on the location of the point on the cross section. For points a, b, c and d on a cross section of this shaft the components of shear stress are shown in the following figure. Note that for points a and c, the non-zero shear stress is τ_{xz} , whereas for points b and d the non-zero shear stress is τ_{xy} . For all other points around the outer perimeter of the shaft, non-zero values for both τ_{xz} and τ_{xy} will exist.

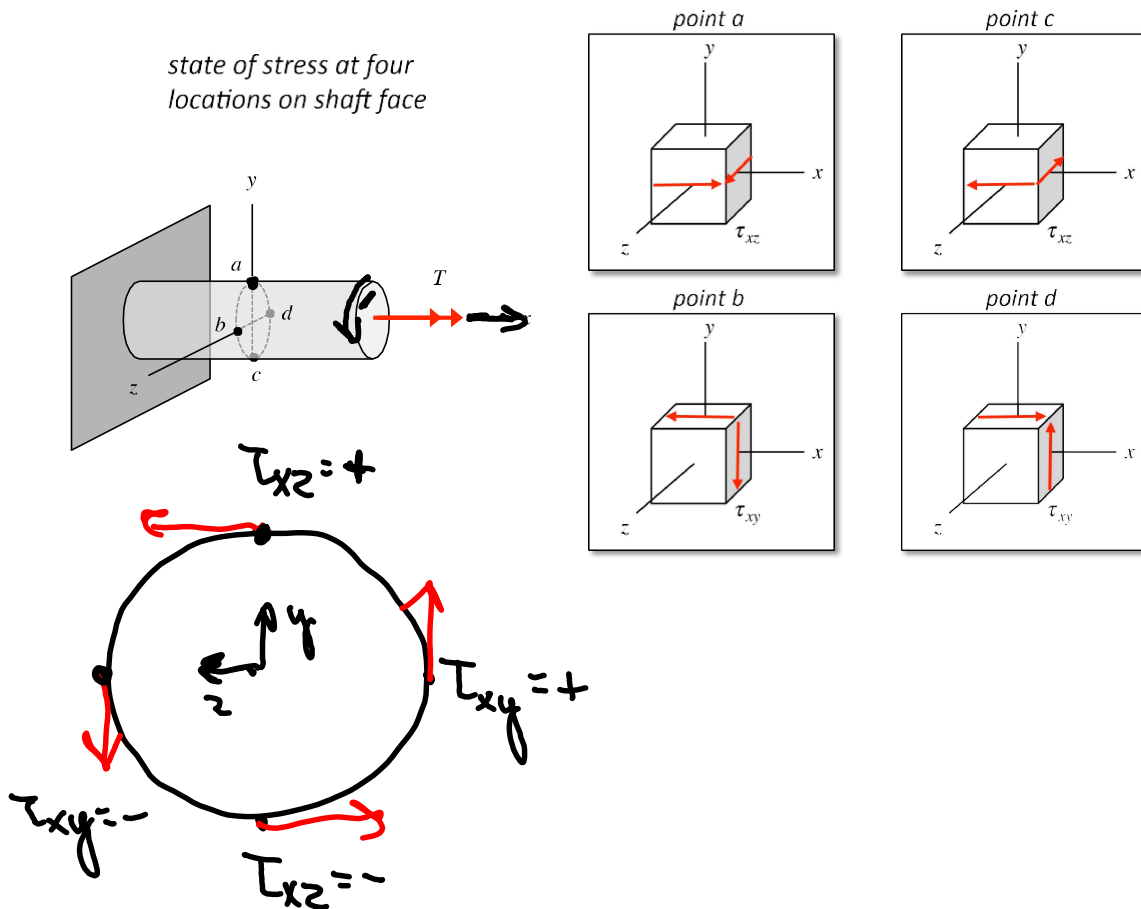

Example 8.1

The solid shaft shown below is made up of an aluminum alloy having an allowable stress of τ_{allow} and a shear modulus of G . The diameter of the shaft is d and its length is $L = \underline{32 \text{ in}}$. If the allowable angle of twist over the length of the shaft is ϕ_{allow} , what is the value of the allowable applied torque T_{allow} ?

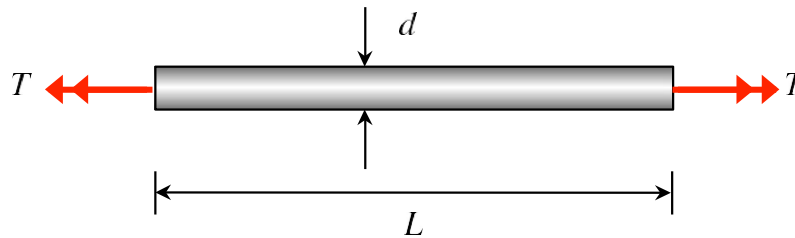

$$\left[\tau = \frac{T R}{I_p} = \tau_{allow} \right]$$

$$I_p = \frac{\pi}{2} \left(\frac{d}{2} \right)^4 = \frac{\pi}{8} d^4$$

$$T_{allow,1} = \frac{I_p \tau_{allow}}{(d/2)} = \frac{\pi d^3 \tau_{allow}}{16}$$

$$\left[\phi_{allow} = \frac{T L}{G I_p} \right]$$

$$T_{allow,2} = \frac{G \left(\frac{\pi d^4}{32} \right) \phi_{allow}}{L} = \frac{G \pi d^4 \phi_{allow}}{32 L}$$

Example 8.3

A stepped steel shaft AC (of material having a shear modulus of G) is subjected to torsional loads at sections B and C, as shown below. The diameters of the two sections of the shaft are d_1 and d_2 .

- a) Determine the maximum shear stress in the shaft. At what location(s) does this maximum shear stress occur?
- b) Determine the angle of twist of the shaft at connector C.

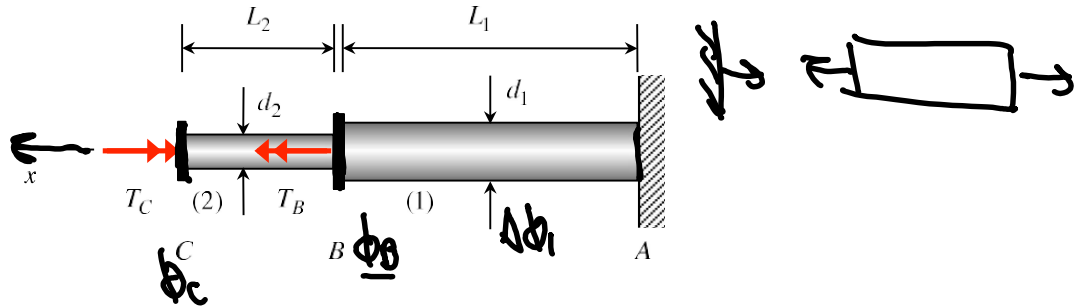

1.)

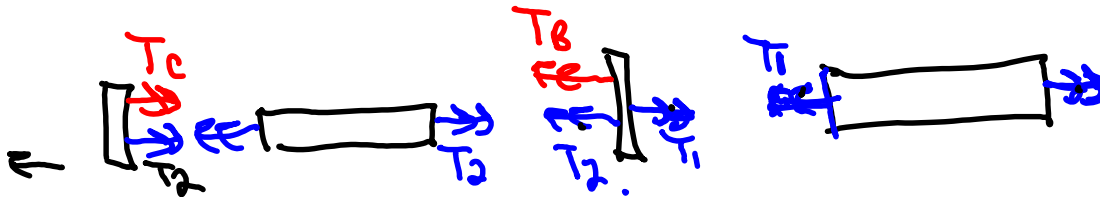

$$\left. \begin{aligned} (\sum M)_C &= -T_2 - T_C = 0 & T_2 &= -T_C \\ (\sum M)_B &= T_2 + T_B - T_1 = 0 & T_1 &= T_B - T_C \end{aligned} \right\} \begin{array}{l} 2 \text{ eqns} \\ 2 \text{ unknowns.} \end{array}$$

$$a) \tau_{max,1} = \frac{T_1 r}{I_p} = \frac{T_1 (d_1/2)}{\frac{\pi}{2} (d_1/2)^4} = \frac{16(T_B - T_C) \epsilon}{\pi d_1^3}$$

$$\tau_{max,2} = \frac{T_2 r}{I_p} = \frac{T_2 (d_2/2)}{\frac{\pi}{2} (d_2/2)^4} = \frac{-16 T_C}{\pi d_2^3} \epsilon$$

$$\int \phi_B - \phi_A = \Delta \phi_0$$

$$\left[\begin{array}{l} \phi_B = \phi_A + \Delta\phi_1 \quad \phi_B = \Delta\phi_1 \\ \phi_C = \phi_B + \Delta\phi_2 \end{array} \right.$$

$$\phi_C = \Delta\phi_1 + \Delta\phi_2 = \frac{T_1 L_1}{G I_p 1} + \frac{T_2 L_2}{G I_p 2}.$$

Example 8.4

A torque of 400 N-m is applied to gear A of a two-shaft system and is transmitted through gears B and C to a fixed end D. The shafts are made of a material having a shear modulus of G , and each shaft has a diameter of $d = 32 \text{ mm}$. The shafts are supported by frictionless bearings.

- Determine the maximum shear stress in each shaft.
- Determine the angular rotation of gear A relative to its unloaded position.

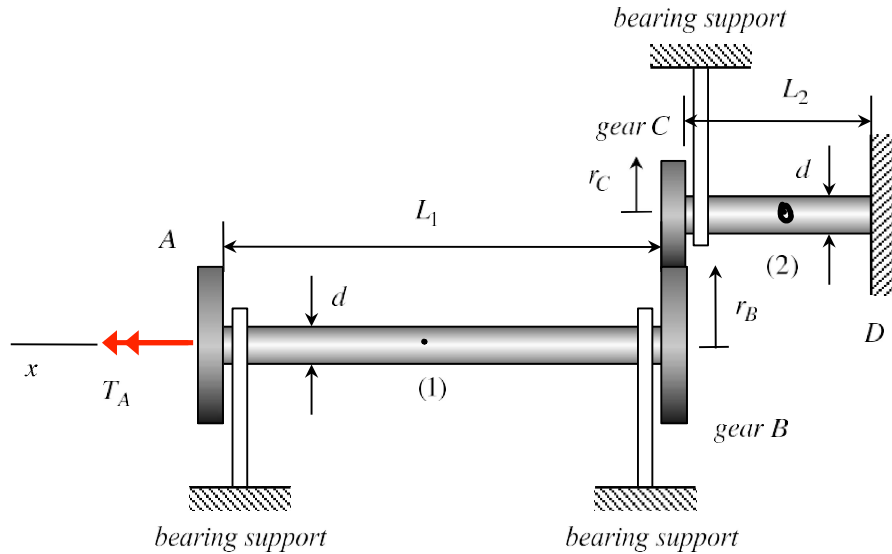

Solution

Step #1 - equilibrium

FBD's:

