

Finite Element Methods

Types of assumptions that we have made so far in this course:

- Members under torsion are cylindrical
- Cross-sections are constant along a beam
- Materials behaviors are linear

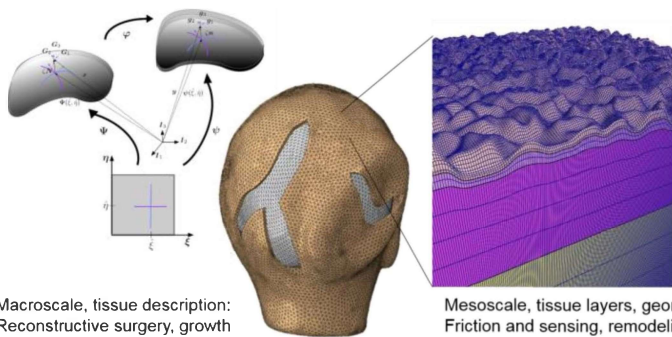
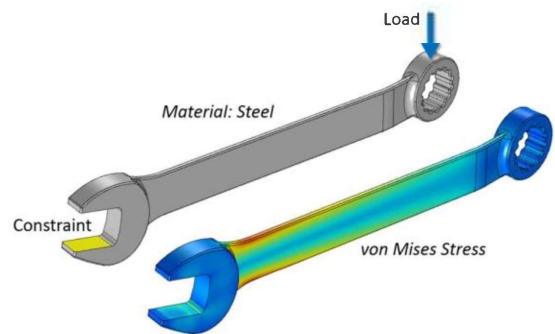
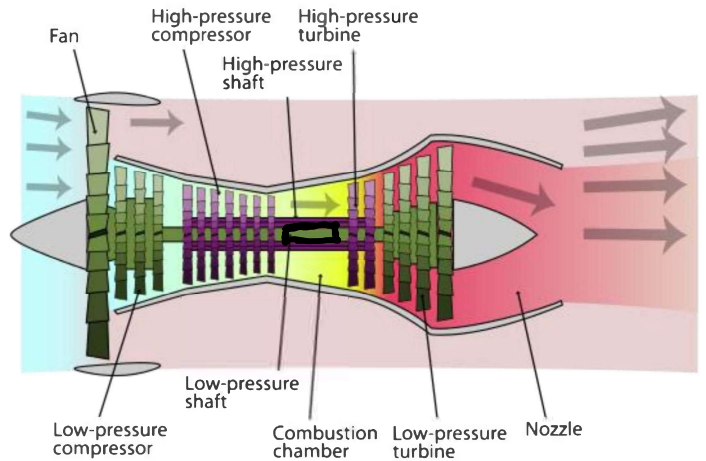

Macroscale, tissue description:
Reconstructive surgery, growth

Mesoscale, tissue layers, geon
Friction and sensing, remodelir



Adrian
Buganza-
Tepole

Andres
Arrieta

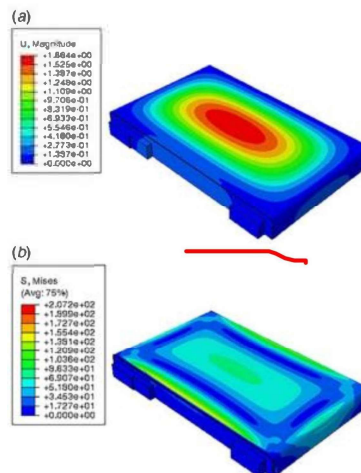
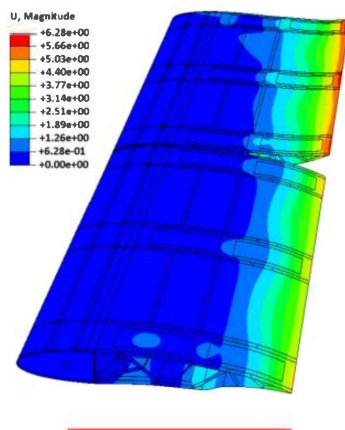
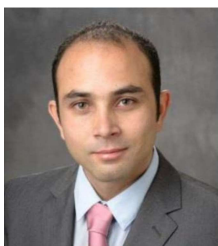

Thomas
Siegmund



Finite Element: Energy Methods in Matrix Form

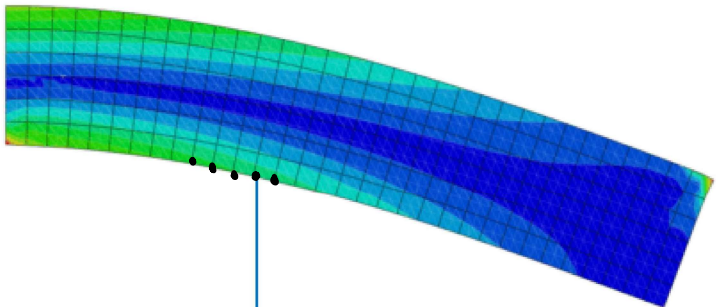
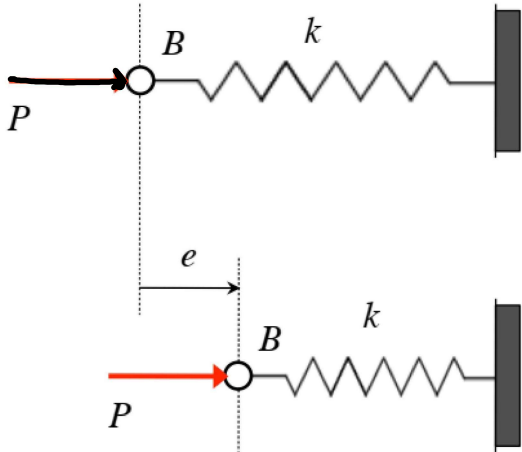

$$W = \left(\frac{1}{2}\right) P e \quad U = \left(\frac{1}{2}\right) k e^2 \quad \left. \vphantom{W} \right] \quad \left. \vphantom{U} \right]$$

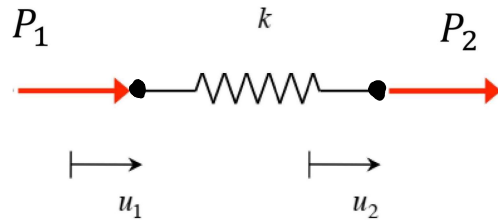

$$U = \left(\frac{1}{2}\right) k \delta^2 = \left(\frac{1}{2}\right) k (u_2 - u_1)^2 \quad \left. \vphantom{U} \right]$$

17. An introduction to the finite element method

Objectives:

To develop and use the finite element equilibrium equations for determining the stress in an axially-loaded structural member.

Background:

Equivalent stiffness for a rod element

Consider the rod element shown below that is of length L with a Young's modulus E and cross-sectional area A (each of which can be a function of position x).

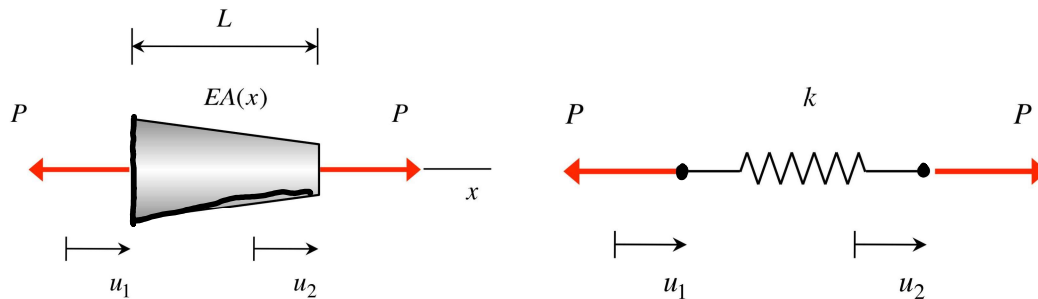

Note that the axial load along the length of the element is a constant value of P . As we have seen before, the elongation of this element is given by:

$$\delta = u_2 - u_1 = \int_0^L \frac{P}{EA} dx = P \int_0^L \frac{1}{EA} dx \approx \frac{PL}{(EA)_{ave}}$$

where u_1 and u_2 are the end displacements of the rod element and $(EA)_{ave}$ is the average value of EA over the element's length. From this we have:

$$\frac{P}{\delta} = \frac{(EA)_{ave}}{L} \quad (1)$$

Consider now the linear spring above of stiffness k . The elongation of the spring is given by:

$$\delta = u_2 - u_1 = \frac{P}{k} \Rightarrow \frac{P}{\delta} = k \quad (2)$$

Comparing the above, we see that the rod can be treated as a spring having a stiffness of:

$$k = \frac{(EA)_{ave}}{L} \quad \frac{E_1 A_1 + E_2 A_2}{L}$$

Strain energy in rods

In general, we can write the strain energy in a body in terms of its strain energy density \bar{u} as:

$$U = \int_{vol} \bar{u} dV$$

where the strain energy density for an axially-loaded rod can be written as:

$$\bar{u} = \frac{1}{2} \varepsilon_x \sigma_x = \frac{1}{2} \left(\frac{du}{dx} \right) \left(E \frac{du}{dx} \right) = \frac{1}{2} E \left(\frac{du}{dx} \right)^2$$

Force potentials

Consider a conservative force F_i acting at point x_i on a rod. The *potential* of this force is defined as

$$\Pi_{F_i} = -F_i u_i$$

↓ take as definition

If M forces act on the rod, the total potential due to these forces is:

$$\Pi_F = -\sum_{i=1}^M F_i u_i$$

System potential energy

The total potential energy for the system Π is defined as the sum of the potential due to the externally-applied forces and the potential due to the strain energy in the system:

$$\Pi = \Pi_F + \Pi_U = -\sum_{i=1}^M F_i u_i + U$$

where U is the strain energy in the system.

Lecture topics:

- Principle of minimum potential energy
- The development of the stiffness matrix for a system of springs
- Finite element method for rods – using the direct method
- Some numerical results from the use of the finite element method on problems in 2D elasticity

Lecture notes

Principle of minimum potential energy

For a given a set of "admissible" displacement fields for a conservative system, an equilibrium state of the system will correspond to a state for which the total potential energy Π is stationary. For a stable equilibrium state, this stationarity will correspond to a minimization of the potential energy.

$$\frac{\partial \Pi}{\partial u} = 0$$

NOTE: An *admissible* displacement field for a rod is one that satisfies all of the displacement boundary conditions of the problem (the boundary conditions related to prescribed forces do not need to be satisfied by the displacement field).

We will use the above principle of minimum potential energy in solving for displacements in the following three rod examples.

$$\Pi = -\sum_i F_i u_i + U \quad \frac{\partial \Pi}{\partial [u]} = -[F] + [K][u] = 0 \quad [K][u] = [F]$$

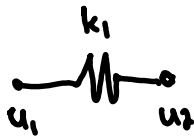

$$U = \frac{1}{2} k (u_2 - u_1)^2$$

$$U = \frac{1}{2} k_1 (u_2^2 - 2u_1 u_2 - u_1^2)$$

$$U = \frac{1}{2} \begin{bmatrix} u_1 \\ u_2 \end{bmatrix}^T \begin{bmatrix} k_1 & -k_1 \\ -k_1 & k_1 \end{bmatrix} \begin{bmatrix} u_1 \\ u_2 \end{bmatrix}$$

stiffness matrix $[K]$.

The stiffness matrix

Before we consider the general form of the equilibrium equations for a rod through the use of the minimum potential energy approach, let us first look at the strain energy in a set of springs that are connected together in series.

Say we consider a single spring of stiffness k , as shown below:

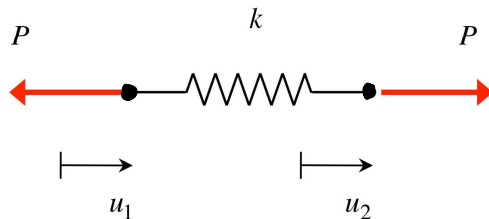

The strain energy in the spring is given by:

$$\begin{aligned} U &= \frac{1}{2} k \delta^2 = \frac{1}{2} k (u_2 - u_1)^2 = \frac{1}{2} k (u_2^2 - 2u_1 u_2 + u_1^2) \\ &= \frac{1}{2} [u_1 (ku_1 - ku_2) + u_2 (-ku_1 + ku_2)] \\ &= \frac{1}{2} \begin{Bmatrix} u_1 \\ u_2 \end{Bmatrix}^T \begin{Bmatrix} ku_1 - ku_2 \\ -ku_1 + ku_2 \end{Bmatrix} \\ &= \frac{1}{2} \begin{Bmatrix} u_1 \\ u_2 \end{Bmatrix}^T \underbrace{\begin{bmatrix} k & -k \\ -k & k \end{bmatrix}}_{[K]} \begin{Bmatrix} u_1 \\ u_2 \end{Bmatrix} = \frac{1}{2} \{u\}^T [K] \{u\} \end{aligned}$$

where $[K]$ is the “stiffness matrix” for the spring.

Consider now two springs, having stiffnesses of k_1 and k_2 , connected in series as shown below:

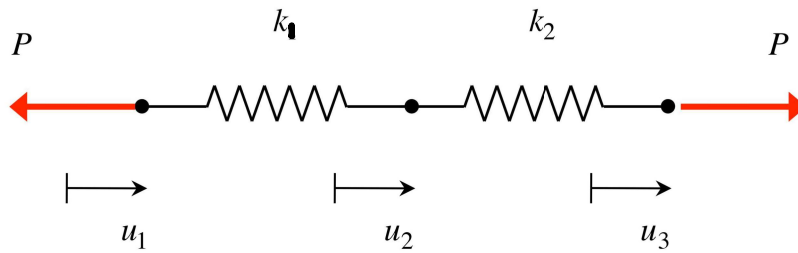

The total strain energy for this system of springs is given by:

$$\begin{aligned}
 U &= \frac{1}{2}k_1(u_2 - u_1)^2 + \frac{1}{2}k_2(u_3 - u_2)^2 \\
 &= \frac{1}{2}k_1(u_2^2 - 2u_1u_2 + u_1^2) + \frac{1}{2}k_2(u_3^2 - 2u_2u_3 + u_2^2) \\
 &= \frac{1}{2} \left[u_1(k_1u_1 - k_1u_2) + u_2(-k_1u_1 + k_1u_2) \right] + \frac{1}{2} \left[u_2(k_2u_2 - k_2u_3) + u_3(-k_2u_2 + k_2u_3) \right] \\
 &= \frac{1}{2} \begin{Bmatrix} u_1 \\ u_2 \\ u_3 \end{Bmatrix}^T \begin{Bmatrix} k_1u_1 - k_1u_2 \\ -k_1u_1 + (k_1 + k_2)u_2 - k_2u_3 \\ -k_2u_2 + k_2u_3 \end{Bmatrix} \\
 &= \frac{1}{2} \begin{Bmatrix} u_1 \\ u_2 \\ u_3 \end{Bmatrix}^T \begin{bmatrix} k_1 & -k_1 & 0 \\ -k_1 & k_1 + k_2 & -k_2 \\ 0 & -k_2 & k_2 \end{bmatrix} \begin{Bmatrix} u_1 \\ u_2 \\ u_3 \end{Bmatrix} = \frac{1}{2} \{u\}^T [K] \{u\}
 \end{aligned}$$

where, again, $[K]$ is the stiffness matrix for the system of springs.

$$\begin{bmatrix} u_1 \\ u_2 \end{bmatrix}^T \begin{bmatrix} k_1 & -k_1 \\ -k_1 & k_1 \end{bmatrix} \begin{bmatrix} u_1 \\ u_2 \end{bmatrix} + \begin{bmatrix} u_2 \\ u_3 \end{bmatrix}^T \begin{bmatrix} k_2 & -k_2 \\ -k_2 & k_2 \end{bmatrix} \begin{bmatrix} u_2 \\ u_3 \end{bmatrix} = \begin{bmatrix} u_1 \\ u_2 \\ u_3 \end{bmatrix}^T \underbrace{\begin{bmatrix} k_1 & -k_1 & 0 \\ -k_1 & k_1 + k_2 & -k_2 \\ 0 & -k_2 & k_2 \end{bmatrix}}_{[K]} \begin{bmatrix} u_1 \\ u_2 \\ u_3 \end{bmatrix}$$

Example 17.1

Use the principle of minimum potential energy to determine the displacement of connector C in the rod.

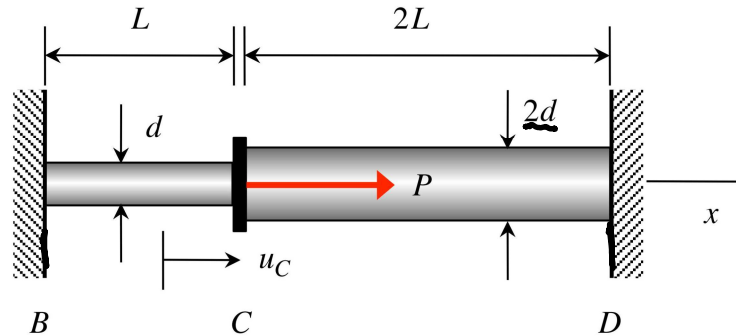

SOLUTION

Here we represent the above rod by the set of two springs in series shown below:

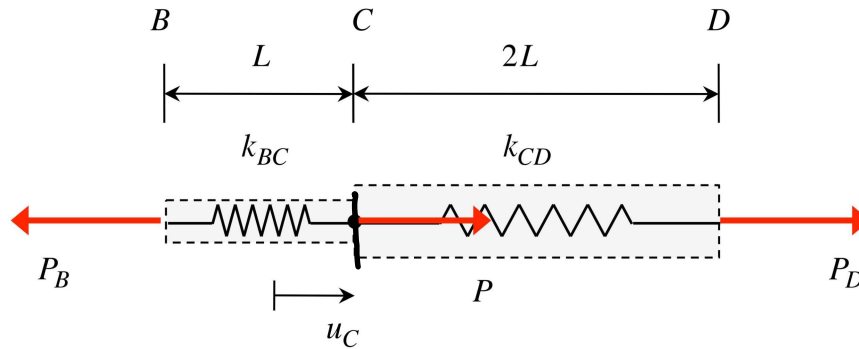

where for $A_0 = \pi d^2 / 4$ we have:

$$k_{BC} = \frac{EA_0}{L}$$

$$k_{CD} = 2 \frac{EA_0}{L} = \frac{(4A_0)E}{2L}$$

$$A_0 = \pi \left(\frac{d}{2}\right)^2$$

The total strain energy in the rod is given by:

$$\Pi_U = U = \frac{1}{2} k_{BC} u_C^2 + \frac{1}{2} k_{CD} u_C^2 = \frac{1}{2} (k_{BC} + k_{CD}) u_C^2$$

and the potential due to the forces is:

$$\Pi_F = -Pu_C - (-P_B)u_B - P_D u_D = -Pu_C$$

From this, we can write the system potential energy as:

$$\Pi = \Pi_F + \Pi_U = -Pu_C + \frac{3EA_0 u_C^2}{2L}$$

strain energy.

Note that the potential energy function is *quadratic* in the connector displacement u_C . The stationarity (minimization) of Π corresponds to the condition that:

$$\frac{\partial \Pi}{\partial u_C} = 0 \Rightarrow -P + \frac{3EA_0 u_C}{L} = 0 \Rightarrow u_C = \frac{PL}{3EA_0}$$

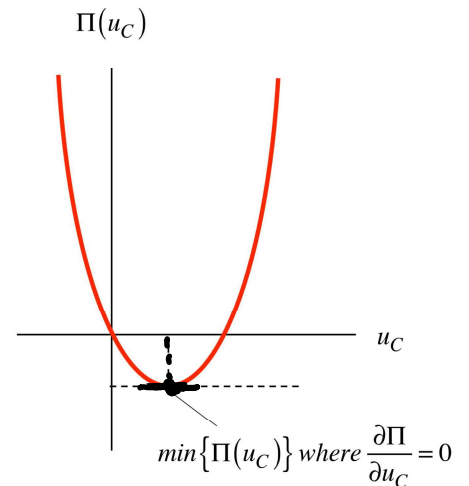

How does this answer for the displacement of C compare with the exact value found using our earlier analysis?

$$[F] = [K][u]$$

$$\begin{bmatrix} k_1 & -k_1 & 0 \\ -k_1 & k_1+k_2 & -k_2 \\ 0 & -k_2 & k_2 \end{bmatrix} \begin{bmatrix} 0 \\ u_2 \\ 0 \end{bmatrix} = \begin{bmatrix} -P_0 \\ P_1 \\ P_0 \end{bmatrix}$$

$$(k_1+k_2)u_2 = P$$

$$u_2 = P \frac{1}{k_1+k_2}$$

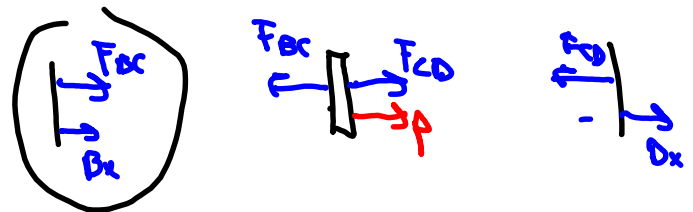

$$F_{BC} = B_x$$

$$-F_{BC} + F_{CD} + P = 0$$

$$-e_{BC} \left(\frac{EA}{L} \right)_{BC} + e_{CD} \left(\frac{EA}{L} \right)_{CD} = -P$$

Example 17.2

Use the principle of minimum potential energy to determine the displacement of connectors C and D in the rod.

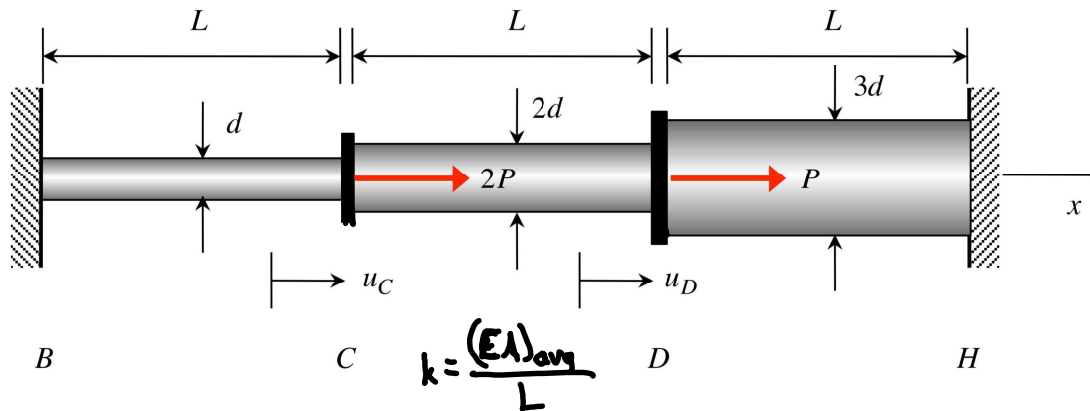

Here we represent the above rod by the set of three springs in series shown below:

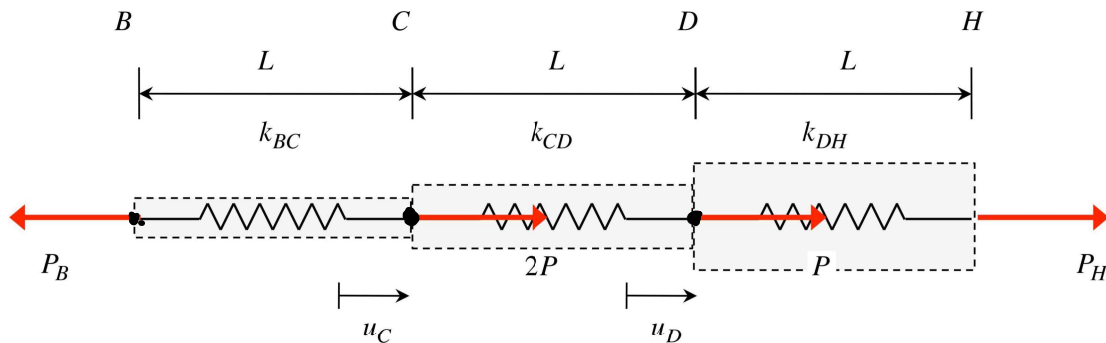

where for $A_0 = \pi d^2 / 4$ we have:

$$\left. \begin{aligned} k_{BC} &= \frac{EA_0}{L} \\ k_{CD} &= \frac{4EA_0}{L} \\ k_{DH} &= \frac{9EA_0}{L} \end{aligned} \right\}$$

The total strain energy in the rod is given by:

$$\Pi_U = U = \frac{1}{2} k_{BC} u_C^2 + \frac{1}{2} k_{CD} (u_D - u_C)^2 + \frac{1}{2} k_{DH} u_D^2$$

The potential energy due to the forces is:

$$\Pi_F = -2Pu_C - Pu_D - (-P_B)u_B - P_H u_H = -2Pu_C - Pu_D$$

From this, we can write the total potential energy as:

$$\underline{\Pi} = \underbrace{\Pi_F}_{\text{Force}} + \underbrace{\Pi_U}_{\text{strain}} = -2Pu_C - Pu_D + \frac{EA_0}{2L} [5u_C^2 - 8u_C u_D + 13u_D^2]$$

We see that the potential energy is a “bowl-shaped” quadratic function of two variables: u_C and u_D (the displacements of connectors C and D). A stationary (minimum) value for Π is found by setting the partial derivatives of Π with respect to the variables u_C and u_D equal to zero:

$$\frac{\partial \Pi}{\partial u_C} = -2P + \frac{EA_0}{L} [5u_C - 4u_D] = 0$$

$$\frac{\partial \Pi}{\partial u_D} = -P + \frac{EA_0}{L} [-4u_C + 13u_D] = 0$$

or,

$$\frac{EA_0}{L} \begin{bmatrix} 5 & -4 \\ -4 & 13 \end{bmatrix} \begin{Bmatrix} u_C \\ u_D \end{Bmatrix} = \begin{Bmatrix} 2P \\ P \end{Bmatrix}$$

Solving the above pair of algebraic equations gives:

$$\begin{Bmatrix} u_C = 0.6122 \frac{PL}{EA_0} \\ u_D = 0.2653 \frac{PL}{EA_0} \end{Bmatrix}$$

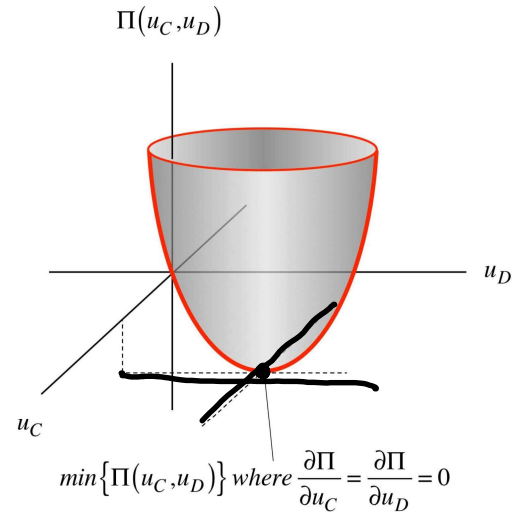

How do these answers for the displacements of C and D compare with the exact values found using our earlier analysis?

The stiffness matrix

Before we consider the general form of the equilibrium equations for a rod through the use of the minimum potential energy approach, let us first look at the strain energy in a set of springs that are connected together in series.

Say we consider a single spring of stiffness k , as shown below:

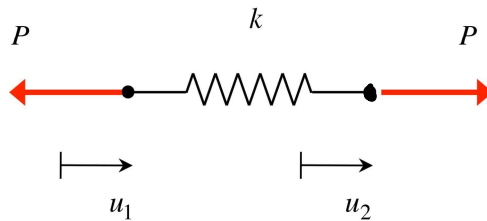

The strain energy in the spring is given by:

$$\begin{aligned} U &= \frac{1}{2} k \delta^2 = \frac{1}{2} k (u_2 - u_1)^2 = \frac{1}{2} k (u_2^2 - 2u_1 u_2 + u_1^2) \\ &= \frac{1}{2} [u_1 (ku_1 - ku_2) + u_2 (-ku_1 + ku_2)] \\ &= \frac{1}{2} \begin{Bmatrix} u_1 \\ u_2 \end{Bmatrix}^T \begin{Bmatrix} ku_1 - ku_2 \\ -ku_1 + ku_2 \end{Bmatrix} \\ &= \frac{1}{2} \begin{Bmatrix} u_1 \\ u_2 \end{Bmatrix}^T \begin{bmatrix} k & -k \\ -k & k \end{bmatrix} \begin{Bmatrix} u_1 \\ u_2 \end{Bmatrix} = \frac{1}{2} \{u\}^T [K] \{u\} \end{aligned}$$

where $[K]$ is the “stiffness matrix” for the spring.

Consider now two springs, having stiffnesses of k_1 and k_2 , connected in series as shown below:

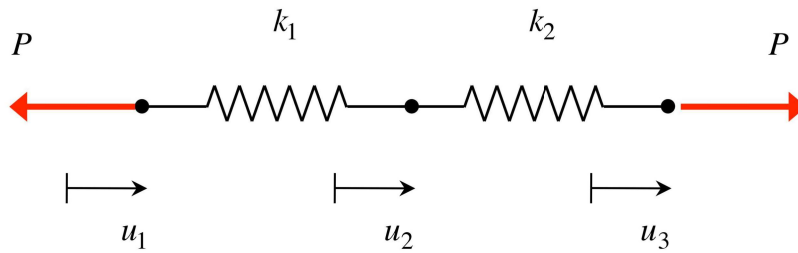

The total strain energy for this system of springs is given by:

$$\begin{aligned}
 U &= \frac{1}{2}k_1(u_2 - u_1)^2 + \frac{1}{2}k_2(u_3 - u_2)^2 \\
 &= \frac{1}{2}k_1(u_2^2 - 2u_1u_2 + u_1^2) + \frac{1}{2}k_2(u_3^2 - 2u_2u_3 + u_2^2) \\
 &= \frac{1}{2}[u_1(k_1u_1 - k_1u_2) + u_2(-k_1u_1 + k_1u_2)] + \frac{1}{2}[u_2(k_2u_2 - k_2u_3) + u_3(-k_2u_2 + k_2u_3)] \\
 &= \frac{1}{2} \begin{Bmatrix} u_1 \\ u_2 \\ u_3 \end{Bmatrix}^T \begin{Bmatrix} k_1u_1 - k_1u_2 \\ -k_1u_1 + (k_1 + k_2)u_2 - k_2u_3 \\ -k_2u_2 + k_2u_3 \end{Bmatrix} \\
 &= \frac{1}{2} \begin{Bmatrix} u_1 \\ u_2 \\ u_3 \end{Bmatrix}^T \begin{bmatrix} k_1 & -k_1 & 0 \\ -k_1 & k_1 + k_2 & -k_2 \\ 0 & -k_2 & k_2 \end{bmatrix} \begin{Bmatrix} u_1 \\ u_2 \\ u_3 \end{Bmatrix} = \frac{1}{2} \{u\}^T [K] \{u\}
 \end{aligned}$$

where, again, $[K]$ is the stiffness matrix for the system of springs.

For a general set of N springs in series:

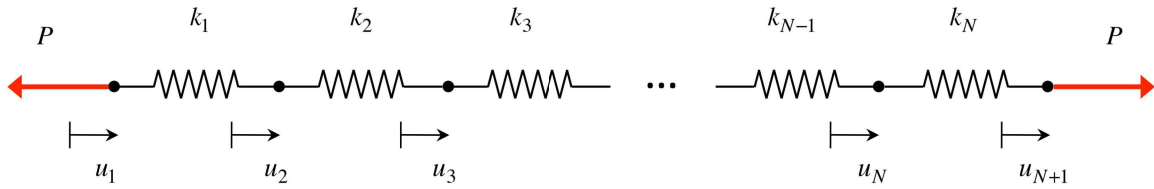

we have:

$$\begin{aligned}
 U &= \frac{1}{2}k_1(u_2 - u_1)^2 + \frac{1}{2}k_2(u_3 - u_2)^2 + \dots + \frac{1}{2}k_N(u_{N+1} - u_N)^2 \\
 &= \frac{1}{2}k_1(u_2^2 - 2u_1u_2 + u_1^2) + \frac{1}{2}k_2(u_3^2 - 2u_2u_3 + u_2^2) + \dots + \frac{1}{2}k_N(u_{N+1}^2 - 2u_Nu_{N+1} + u_N^2) \\
 &= \frac{1}{2}[u_1(k_1u_1 - k_1u_2) + u_2(-k_1u_1 + k_1u_2)] + \frac{1}{2}[u_2(k_2u_2 - k_2u_3) + u_3(-k_2u_2 + k_2u_3)] \\
 &\quad + \dots + \frac{1}{2}[u_N(k_Nu_N - k_Nu_{N+1}) + u_{N+1}(-k_Nu_N + k_Nu_{N+1})]
 \end{aligned}$$

$$= \frac{1}{2} \begin{Bmatrix} u_1 \\ u_2 \\ \vdots \\ u_N \\ u_{N+1} \end{Bmatrix}^T \begin{Bmatrix} k_1u_1 - k_1u_2 \\ -k_1u_1 + (k_1 + k_2)u_2 - k_2u_3 \\ \vdots \\ -k_Nu_{N-1} + (k_{N-1} + k_N)u_N - k_Nu_{N+1} \\ -k_Nu_N + k_Nu_{N+1} \end{Bmatrix}$$

$$= \frac{1}{2} \begin{Bmatrix} u_1 \\ u_2 \\ \vdots \\ u_N \\ u_{N+1} \end{Bmatrix}^T \begin{bmatrix} k_1 & -k_1 & 0 & \dots & \dots & \dots & \dots \\ -k_1 & k_1 + k_2 & -k_2 & 0 & \dots & \dots & \dots \\ 0 & -k_2 & k_2 + k_3 & -k_3 & \dots & \dots & \dots \\ \vdots & 0 & -k_3 & k_3 + k_4 & \dots & \dots & \dots \\ \vdots & \vdots & \vdots & \vdots & \ddots & \ddots & -k_{N-1} & 0 \\ \vdots & \vdots & \vdots & 0 & -k_{N-1} & k_{N-1} + k_N & -k_N & \vdots \\ \vdots & \vdots & \vdots & \vdots & 0 & k_N & k_N & \vdots \end{bmatrix} \begin{Bmatrix} u_1 \\ u_2 \\ \vdots \\ u_N \\ u_{N+1} \end{Bmatrix}$$

$$= \frac{1}{2} \{u\}^T [K] \{u\}$$

$$= \frac{1}{2} \sum_{i=1}^{N+1} \sum_{j=1}^{N+1} K_{ij} u_i u_j$$

Observations

- a) As seen in the results above, the strain energy for a set of springs connected in series is represented by the “matrix inner product” $\{u\}^T [K] \{u\} / 2$, where $[K]$ is the “stiffness matrix” and $\{u\}$ is a vector of displacements.
- b) Note that the stiffness matrix $[K]$ is *symmetric*; that is, $[K] = [K]^T$ (if you interchange its rows and columns, the matrix is unchanged). For us here, we can use this as a check to insure that we have constructed the matrix correctly (that is, if the matrix in the end is not symmetric, we have made a mistake). There are other, more physical implications related to this symmetry.
- c) The stiffness matrix is of a “tridiagonal” structure: the major diagonal has one super-diagonal and one sub-diagonal, with the remaining elements of the matrix being zero. This structure shows how displacements of only adjacent spring nodes are coupled in this formation of the strain energy.
- d) Recall that the stiffness matrix for a single spring of stiffness k_i was found to be:

$$[k^{(i)}] = \begin{bmatrix} k_i & -k_i \\ -k_i & k_i \end{bmatrix}$$

The total stiffness matrix $[K]$ is formed from a combination of these individual spring stiffness matrices along the tridiagonals of $[K]$ as:

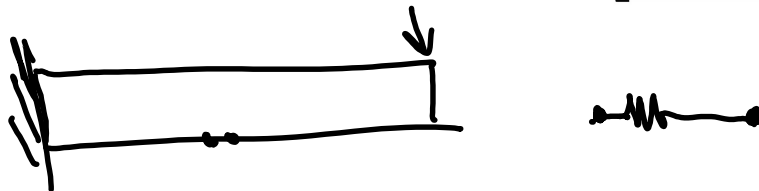
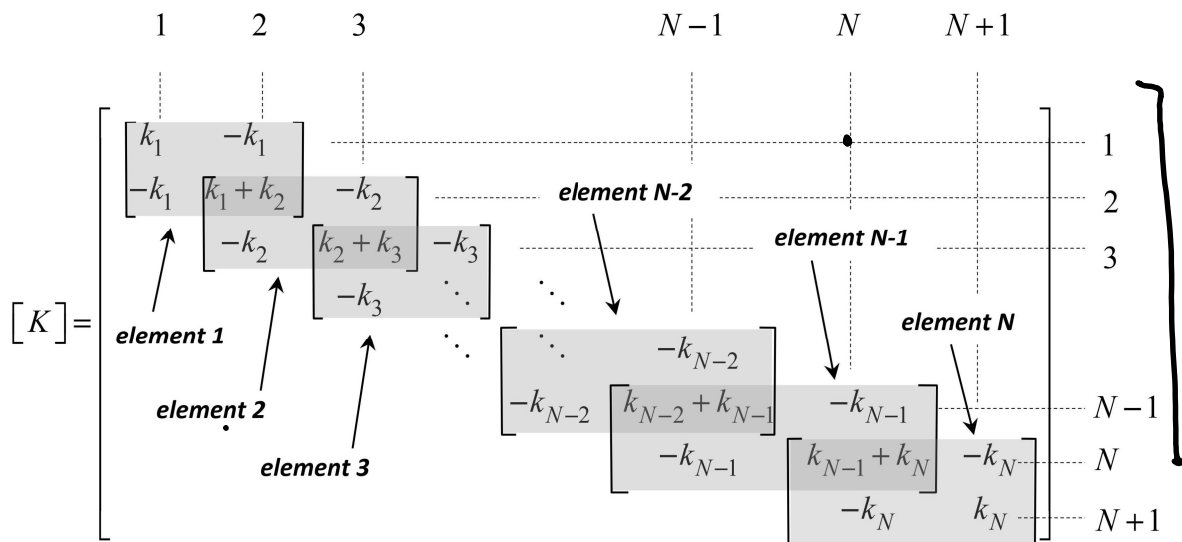

specific to 1D systems.

The finite element equations for rods – direct method

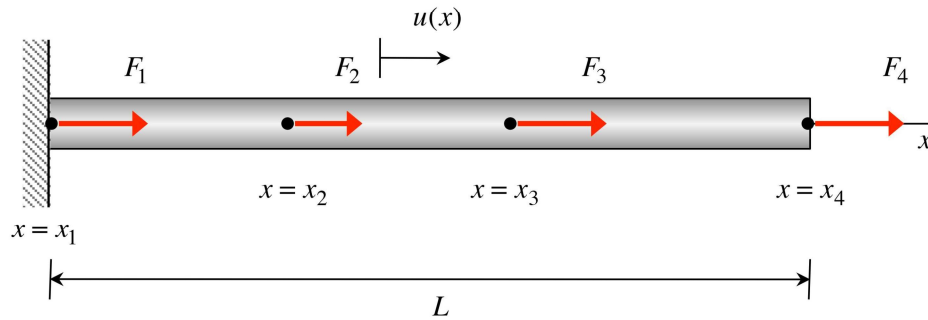

Consider here the axial motion $u(x)$ for a rod of length L under the action of a number of *EXTERNAL* axial loads F_i , where the value of EA in the rod can vary with position x . For our analysis, we will subdivide the rod into a set of N “elements” with the length of the i^{th} element being L_i . A set of $N+1$ “nodes” at $x = x_1, x_2, \dots, x_N, x_{N+1}$ will define the boundaries of these elements. Acting at a given node is an *EXTERNAL* “nodal force” F_i ; $i = 1, 2, \dots, N + 1$. These elements and nodes are shown below.

Recall that the stiffness of the i^{th} element of the rod can be represented by:

$$k_i = \frac{(EA)_i}{L_i}$$

where $(EA)_i$ is the average value of EA over the i^{th} element. With this, we replace the rod by a set of springs in series, as shown below, with each spring representing the stiffness of the corresponding element of the rod.

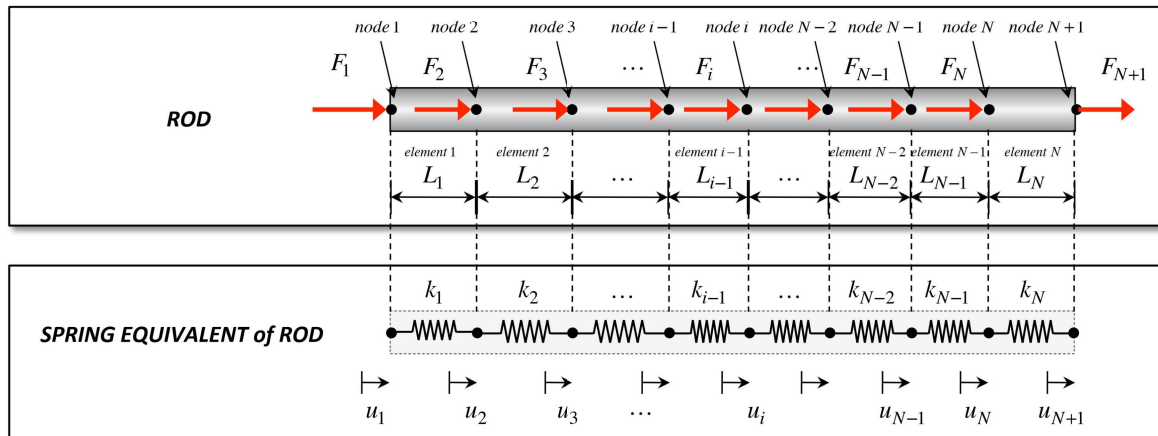

a) Potential due to externally-acting forces acting on a rod

Here we have *external* forces F_i acting at nodes x_i ; $i = 1, 2, \dots, N + 1$ on the rod. The potential of these forces is given by:

$$\Pi_F = - \sum_{i=1}^{N+1} F_i u_i$$

b) Strain energy in a rod

As we are viewing the rod as a set of springs in series, the strain energy for the rod can be written as:

$$\Pi_U = U = \frac{1}{2} \sum_{i=1}^{N+1} \sum_{j=1}^{N+1} K_{ij} u_i u_j$$

where:

$$[K] = [K_{ij}] = \begin{bmatrix} k_1 & -k_1 & 0 & \dots & \dots & \dots & \dots \\ -k_1 & k_1 + k_2 & -k_2 & 0 & \dots & \dots & \dots \\ 0 & -k_2 & k_2 + k_3 & -k_3 & \ddots & \dots & \dots \\ \vdots & 0 & -k_3 & k_3 + k_4 & \ddots & 0 & \dots \\ \vdots & \vdots & \ddots & \ddots & \ddots & -k_{N-1} & 0 \\ \vdots & \vdots & \vdots & 0 & -k_{N-1} & k_{N-1} + k_N & -k_N \\ \vdots & \vdots & \vdots & \vdots & 0 & -k_N & k_N \end{bmatrix}$$

is the stiffness matrix for the rod.

c) The total potential energy

The TOTAL potential energy of the system can be written as the sum of the potential of the applied external forces Π_F and the strain energy Π_U in the rod:

$$\Pi = \Pi_F + \Pi_U = - \sum_{i=1}^{N+1} F_i u_i + \frac{1}{2} \sum_{i=1}^{N+1} \sum_{j=1}^{N+1} K_{ij} u_i u_j$$

Finite element equilibrium equations

The potential energy expression for the finite element model of a rod can be expressed as:

$$\Pi = - \sum_{k=1}^{N+1} F_k u_k + \frac{1}{2} \sum_{k=1}^{N+1} \sum_{p=1}^{N+1} K_{kp} u_k u_p$$

where F_i are the concentrated forces acting on the $N+1$ nodes of the rod and $[K]$ is the stiffness matrix derived earlier for the rod. With the potential energy being written in terms of the $N+1$ nodal displacements u_i ; $i = 1, 2, \dots, N+1$, the minimum potential energy theorem says that the equilibrium state of the rod is described by the following set of equations for $i = 1, 2, \dots, N+1$:

$$\begin{aligned} \frac{\partial \Pi}{\partial u_i} &= - \frac{\partial}{\partial u_i} \left(\sum_{k=1}^{N+1} F_k u_k \right) + \frac{\partial}{\partial u_i} \left(\frac{1}{2} \sum_{k=1}^{N+1} \sum_{p=1}^{N+1} K_{kp} u_k u_p \right) \\ 0 &= - \sum_{k=1}^{N+1} F_k \frac{\partial u_k}{\partial u_i} + \frac{1}{2} \sum_{k=1}^{N+1} \sum_{p=1}^{N+1} K_{kp} \frac{\partial u_k}{\partial u_i} u_p + \frac{1}{2} \sum_{k=1}^{N+1} \sum_{p=1}^{N+1} K_{kp} u_k \frac{\partial u_p}{\partial u_i} ; \text{ product rule} \\ &= -F_i + \frac{1}{2} \sum_{p=1}^{N+1} K_{ip} u_p + \frac{1}{2} \sum_{k=1}^{N+1} K_{ki} u_k \\ &= -F_i + \frac{1}{2} \sum_{p=1}^{N+1} K_{ip} u_p + \frac{1}{2} \sum_{k=1}^{N+1} K_{ik} u_k ; K_{ip} = K_{pi} \text{ (symmetric stiffness matrix)} \\ &= -F_i + \sum_{p=1}^{N+1} K_{ip} u_p \end{aligned}$$

or,

$$\sum_{p=1}^{N+1} K_{ip} u_p = F_i \Rightarrow [K]\{u\} = \{F\}$$



Enforcement of boundary conditions

Recall that the displacement field used in the derivation of the equilibrium equations is to be “admissible”; that is, it must satisfy the displacement boundary conditions of the problem. If the k^{th} node is fixed, we effectively set $u_k = 0$. The enforcement of this fixed boundary condition can be brought about by eliminating the k^{th} column of the stiffness matrix $[K]$, eliminating the k^{th} row of $[K]$ and the k^{th} row of the force vector $\{F\}$.

To demonstrate this, suppose that for a fixed-free rod, where the end at $x = L$ is fixed, we have developed a set of equilibrium equations using 4 nodes ($N = 4$). Therefore, the 4^{th} node is fixed, $u_4 = 0$. With the set of equilibrium equations we strike out the fourth column and row of the stiffness matrix and the fourth row of the force vector:

$$\begin{bmatrix} K_{11} & K_{12} & 0 & 0 \\ K_{21} & K_{22} & K_{23} & 0 \\ 0 & K_{32} & K_{33} & K_{34} \\ \underline{0} & \underline{0} & \underline{K_{43}} & \underline{K_{44}} \end{bmatrix} \begin{bmatrix} u_1 \\ u_2 \\ u_3 \\ \underline{u_4} \end{bmatrix} = \begin{bmatrix} F_1 \\ F_2 \\ F_3 \\ \underline{F_4} \end{bmatrix}$$

This leaves us with a 3×3 stiffness matrix and a force vector with 3 rows:

$$\begin{bmatrix} K_{11} & K_{12} & 0 \\ K_{21} & K_{22} & K_{23} \\ 0 & K_{32} & K_{33} \end{bmatrix} \begin{bmatrix} u_1 \\ u_2 \\ u_3 \end{bmatrix} = \begin{bmatrix} F_1 \\ F_2 \\ F_3 \end{bmatrix}$$

$k_{11}u_1 + k_{12}u_2 = F_1$
 $k_{12}u_1 - k_{11}u_2 = F_1$

Calculation of stress

Recall that the internal axial load carried by the i^{th} axially-loaded component is given by:

$$\underline{P}_i = k_i(u_{i+1} - u_i) = \frac{(EA)_i}{L_i}(u_{i+1} - u_i)$$

From this, we can express the axial stress in this component as:

$$\underline{\sigma}_i = \frac{P_i}{A_i} = \frac{E_i}{L_i}(u_{i+1} - u_i)$$

Once the equilibrium equations $[K]\{u\} = \{F\}$ are solved for the nodal displacements, we can determine the average stress across the i^{th} element using the above relationship.

Method

Consider the following steps in setting up and solving the finite element displacement equations:

- Defining the nodes and elements for the problem. Choose a set of $N+1$ nodes along the length of the rod at locations $x_1 (= 0), x_2, x_3, \dots, x_N, x_{N+1} (= L)$. The subdomain of $x_i < x < x_{i+1}$ is known as the i^{th} element of length $L_i = x_{i+1} - x_i$, for $i = 1, 2, \dots, N$. The value of $k_i = (EA)_i / L_i$ is determined through the average value of EA over the i^{th} element and the element length L_i .
- Constructing the global stiffness matrix. Construct the stiffness matrix $[K]$. The resulting matrix will be tri-diagonal and of size $(N+1) \times (N+1)$.
- Constructing the force vector
Construct the force vector $\{F\}$ as being made up on the resultant external force acting on each node. The resulting vector will be of length $N+1$.
- Enforcing fixed-displacement boundary conditions. The fixed-displacement boundary conditions are enforced through the elimination of appropriate terms in the resulting stiffness matrix $[K]$ and forcing vector $\{F\}$. For example, if the i^{th} node has a fixed (zero) displacement, we eliminate the i^{th} row and i^{th} column of $[K]$ and the i^{th} row of $\{F\}$. If the problem has “n” fixed nodal displacements, then the stiffness matrix and force vector will be of sizes $(N-n+1) \times (N-n+1)$ and $N-n+1$, respectively¹.
- Solving. The nodal displacements u_k ; $k = 1, 2, \dots, N-n+1$ are found from the solution of the algebraic equilibrium equations:
$$[K]\{u\} = \{F\}$$
through a linear equation solver in an application such as Matlab or Mathematica.
- Stress calculations
The average stress across the i^{th} element is found from:

$$\sigma_i = \frac{E_i}{L_i}(u_{i+1} - u_i)$$

A Matlab code for constructing the stiffness matrix and force vector for a general N-element finite element mesh, for enforcing fixed-displacement boundary conditions and solving for the displacement of the non-fixed nodes is shown on the following page.

¹ If no displacement boundary conditions are applied, the rod will be physically unconstrained against motion. Consequently, there will be no equilibrium solution possible. The stiffness matrix for an unconstrained system will be singular, and therefore, non invertible.

Example 17.3

FEM.

Use the principle of minimum potential energy to determine the displacement of end B in the rod.

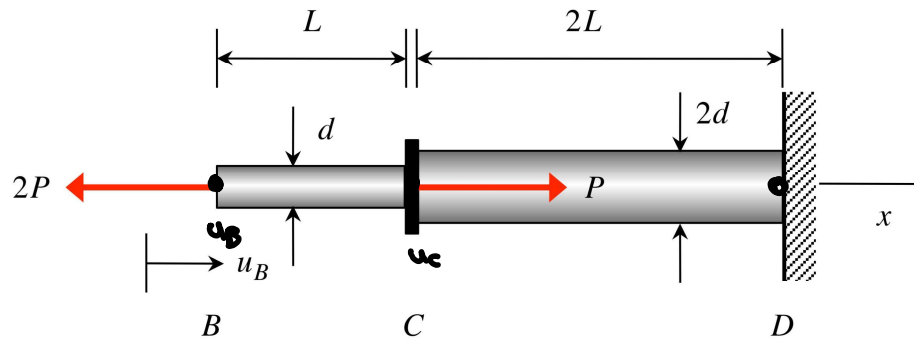

$$k_1 = \frac{EA_0}{L} \quad k_2 = \frac{2EA_0}{L}$$

1.) Generate matrices.

$$\begin{bmatrix} k_1 & -k_1 & 0 \\ -k_1 & k_1+k_2 & -k_2 \\ 0 & -k_2 & k_2 \end{bmatrix} \begin{bmatrix} u_B \\ u_C \\ 0 \end{bmatrix} = \begin{bmatrix} -2P \\ P \\ P_0 \end{bmatrix}$$

2.) Reduce matrix

$$\begin{bmatrix} k_1 & -k_1 \\ -k_1 & k_1+k_2 \end{bmatrix} \begin{bmatrix} u_B \\ u_C \end{bmatrix} = \begin{bmatrix} -2P \\ P \end{bmatrix}$$

3.) Solve

$$\frac{EA_0}{L} \begin{bmatrix} 1 & -1 \\ -1 & 3 \end{bmatrix} \begin{bmatrix} u_B \\ u_C \end{bmatrix} = \begin{bmatrix} -2P \\ P \end{bmatrix}$$

$$\begin{aligned} u_B - u_C &= -2P \left(\frac{L}{EA_0} \right) \\ -u_B + 3u_C &= P \left(\frac{L}{EA_0} \right) \\ 2u_C &= -P \left(\frac{L}{EA_0} \right) \\ u_C &= -\frac{PL}{2EA_0} \end{aligned}$$