

1. Review of Static Equilibrium

Objectives:

To review fundamental principles and methods used for solving equations of static equilibrium of bodies.

Background:

- *Equations of equilibrium* - for a body acting upon by three-dimensional forces ($\vec{F}_1, \vec{F}_2, \vec{F}_3, \dots$) and force-couples ($\vec{M}_1, \vec{M}_2, \vec{M}_3, \dots$) we have the following six scalar equations of equilibrium:

$$\begin{aligned}\sum F_x &= 0 & (\sum M_x)_O &= 0 \\ \sum F_y &= 0 & (\sum M_y)_O &= 0 \\ \sum F_z &= 0 & (\sum M_z)_O &= 0\end{aligned}$$

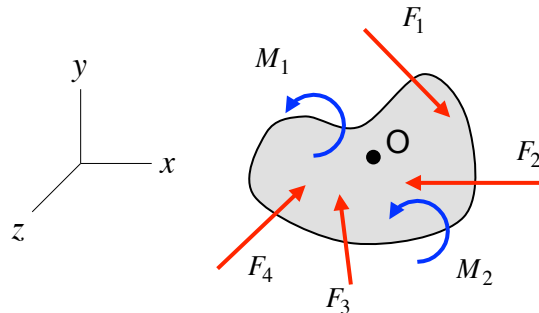

- *Rigid body assumptions* – deformations due to loadings are irrelevant in subsequent force analysis. Consequences of rigid body assumptions:
 - Can replace a force system by an equivalent force-couple system. Two different force systems have equivalent effects on a rigid body if the forces in each system have the same force resultant and exert the same total moment about any point on the body.
 - The point of application for a couple on rigid body does not influence the moment produced by the couple; i.e., a couple acting at a point on the rigid body has the same effect on the body regardless of the location of the point of application.

Lecture topics:

- a) Drawing free body diagrams (FBDs)
- b) External reactions and redundant constraints (static indeterminacy)
- c) Equivalent force couple-systems and internal resultants

Drawing free body diagrams

Drawing free body diagrams (FBDs) is the cornerstone of all work in this course. From these FBDs we will derive equilibrium relations that, along with kinematics and material property information, produce the equations needed to determine states of stress. It is often the case that choosing the correct FBDs to draw is the first step in this solution process. Free body diagrams are needed for the determination of the external reaction forces and couples. Once the external reactions are found, internal reaction forces and couples are also found, typically using a different set of FBDs.

When drawing FBDs in this course, consider the following set of guidelines:

- i. Determine the body/bodies to be included in the FBD. Isolate the body from its supports and/or other bodies to which it is attached. Include an appropriate set of coordinate axes onto which the force/couple vectors are to be projected.
- ii. Indicate on the FBD a sketch of all applied loads, including both applied and reaction forces/couples. Consider the following table reactions due to some common connections to supports and connecting bodies.
- iii. Label significant points and significant dimensions.
- iv. When writing down equilibrium equations from the FBD, be sure to follow a set of sign conventions that are consistent with the set of coordinate axes chosen above. From these equilibrium equations can be found the external reactions acting on the body represented by the FBD.

An important note on support reactions

Each support of a structure constrains either a displacement or rotation of the structure. The support reaction forces and couples generated at the support are those forces and couples that are necessary for the enforcement of these constraints. Carefully study the table below to familiarize yourself with the support reactions associated with the different supports/constraints shown. The results shown here are needed by you in drawing the FBDs needed for equilibrium analysis.

boundary condition	reaction	boundary condition	reaction

Special case: two-force members

Recall that a two-force member is a structural component with forces acting on the component at only two locations. From equilibrium relations we can show that the resultant load on the component is a pair of equal and opposite forces acting at these two points with the line of action of this pair of forces aligned with the line connecting these two points. This is shown below.

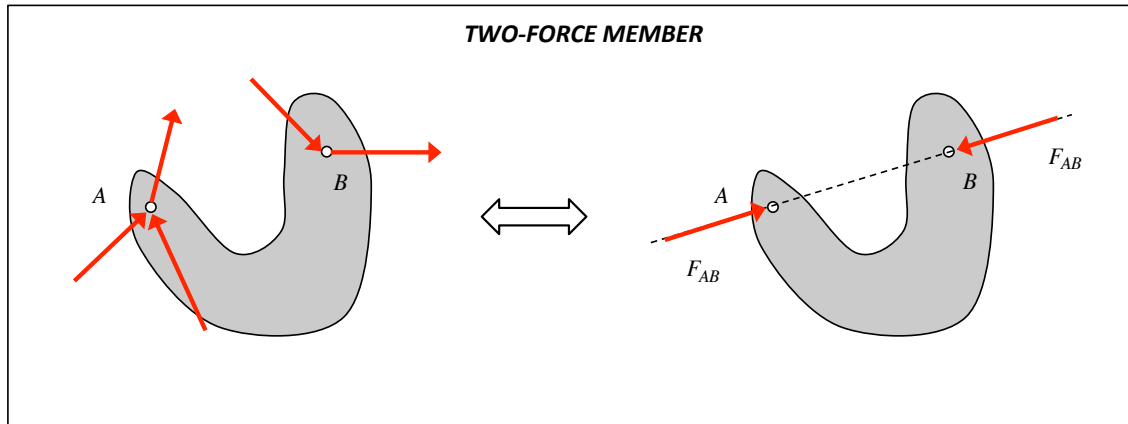

When drawing FBDs of structural components, it is convenient to take advantage of the simplicity of a two-force member when they exist. Trusses are made up exclusively of two-force members. Other structures, such as frames, contain two-force members along with members having more complicated boundary conditions.

External reactions

Typically, the first step in equilibrium analysis of a structure is to determine the reaction loads acting on the body by external restraints.

- For many problems, external reactions can be found from equilibrium equations derived from a free body diagram of the body. In that case, the structure is said to be “statically determinate” since the reactions can be found using only static equilibrium considerations.
- For other problems, the structure is over constrained by its external reactions, and the number of unknown reaction loads exceeds the number equilibrium equations available. In this case, the structure is said to be “statically indeterminate.” As we will see later on, the external reactions can be found considering both equilibrium relations along with deformation analysis of the structure. Note that the expression “static indeterminacy” does *not* imply that the problem is not “solvable”; the expression simply implies that information beyond equilibrium equations are required for a solution. We will deal with many statically indeterminate structures throughout this course.

Internal resultants

Secondly, throughout the course we will be determining “internal resultants” for structural components. These resultants represent equivalent force/couple systems for distributed loadings that exist on cut surfaces in the member, where these mathematical cuts are made to expose the stress distributions within the member. Consider the following example of a point force applied at the free end of a bent bar. Making a mathematical cut in the bar at location A exposes the following internal resultants: axial force F_x , a shear force V_y , a torque T_x and bending moments M_y and M_z . Note that these resultants appear in equal and opposite pairs on each side of the cut at A. These resultants are readily found from equilibrium analysis; e.g., using the equilibrium equations of $\sum \vec{F} = \vec{0}$ and $\sum \vec{M}_A = \vec{0}$ produces five non-trivial equations for these five resultants.

Note that these resultants on a given face are actually the components of the equivalent force/couple system for the internal stress distributions on that face. Specifically, F_x , M_y and M_z are the components of the equivalent force/couple system due to the normal stress at A, whereas V_y and T_x result from the shear stresses at A. As in this example, the determination of the internal resultants is simply found from equilibrium analysis. Determining the stress distributions that produce these resultants is generally not a simple process; this process will be a significant effort for us in this course.

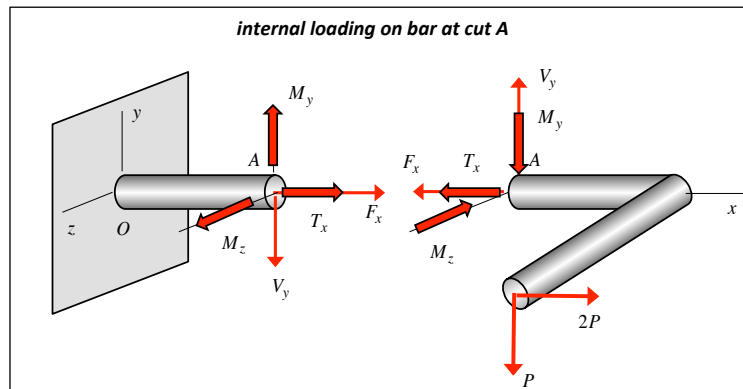
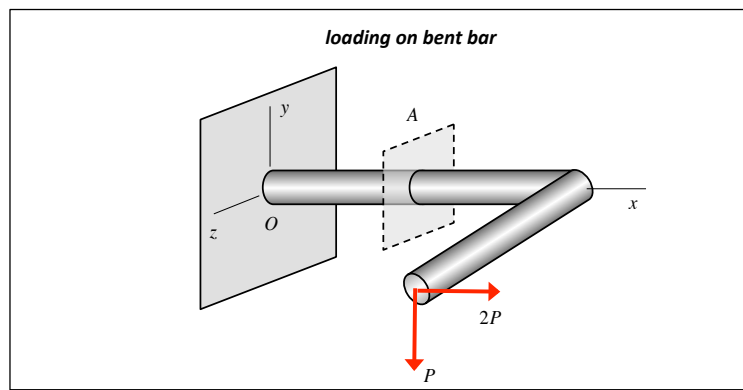

Important notes on internal resultants:

- Internal resultants depend on the location and orientation of the section cut. In the bent pipe example above, these resultants depend on the x -location along the pipe.
- The internal resultant forces and couples acting on one side of the cut are equal and opposite to the internal resultant forces and couples acting on the other side of the cut.

Example 1.1

Complete the free body diagrams below. Which of the following systems are statically determinate for the support reactions?

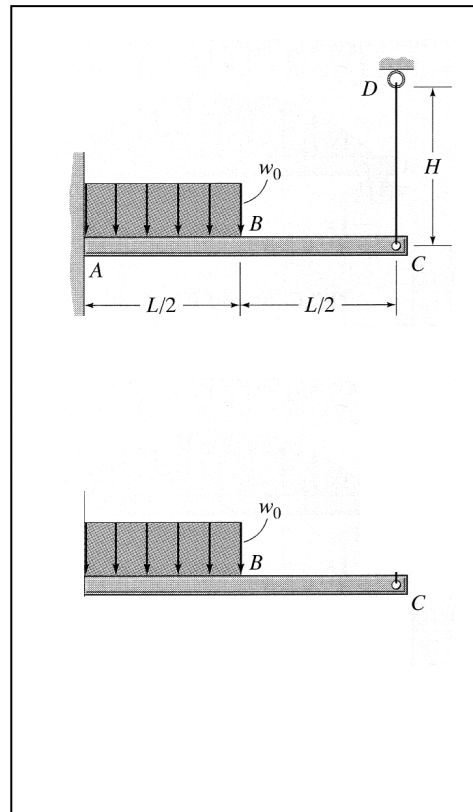
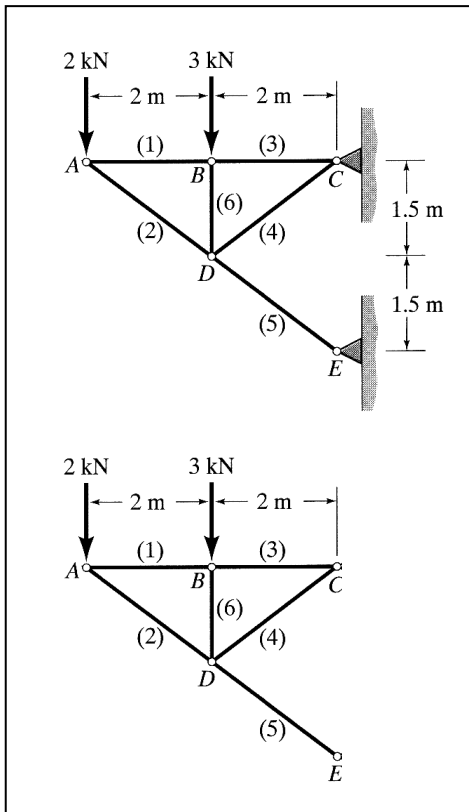
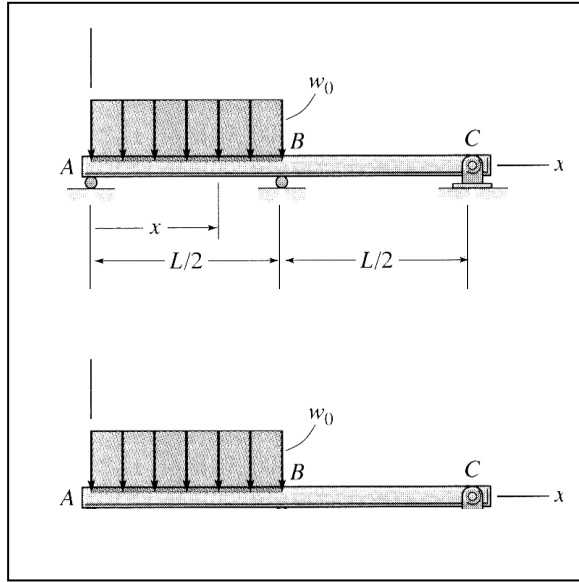
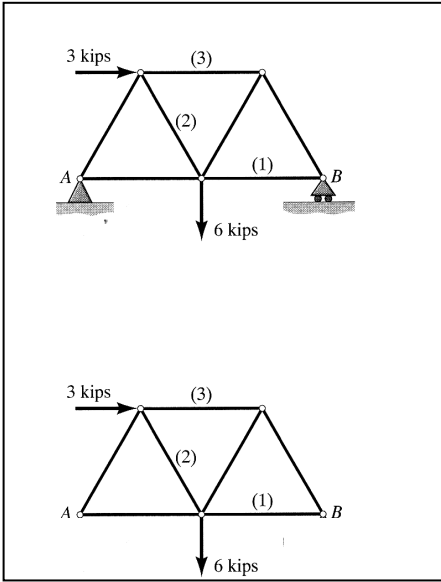

Example 1.3

The uniform distributed load on member AC has a magnitude of p_0 . Determine the internal axial force, shear force and bending moment acting on the left face of the cross section of member AC at G.

