

## ***2. Normal stress, extensional strain and material properties***

### **Objectives:**

To study the relationship between stress and strain during the uni-axial loading of a member.

### **Background:**

- *Stress* is defined as the distribution of a force acting over an area (stress = force per unit area).
- *Extensional strain* is defined as the elongation/shortening of an element divided by the original length of the element (extensional strain = elongation/shortening per unit length).

### **Lecture topics:**

- a) Normal stress resultants
- b) Extensional strains and Poisson's ratio
- c) Mechanical properties of materials from uni-axial tests

## Lecture Notes

### a) Normal stress resultants

Uni-axial loading of member having a cross-sectional area  $A$  by an axial force  $P$ :

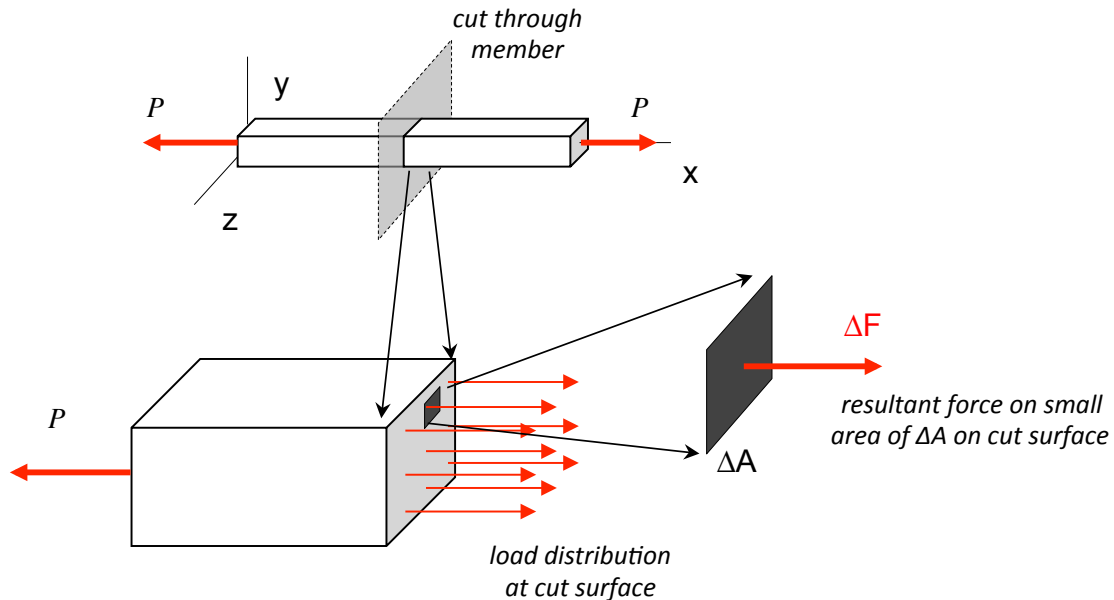

Let  $\Delta F$  represent the resultant force acting at the cut over an area of  $\Delta A$  on the cross section of the cut. From this, we can write:

$$\sigma_x = \text{normal stress} = \lim_{\Delta A \rightarrow 0} \left( \frac{\Delta F}{\Delta A} \right) = \frac{dF}{dA} \Rightarrow dF = \sigma_x dA$$

### Average normal stress

From the above and using equilibrium of the member section to the left of the cut, we have:

$$P = \int_{\text{area}} dF = \int_{\text{area}} \sigma_x dA = \text{total resultant force on the cross-section}$$

Using the definition of the “average” value of a function over an area:

$$(\sigma_x)_{\text{ave}} = \frac{1}{A} \int_{\text{area}} \sigma_x dA$$

we see that,

$$(\sigma_x)_{\text{ave}} = \frac{P}{A}$$

### Some assumptions and their consequences

- If the axial load  $P$  acts at the centroidal position of the member's cross section;
- if the material of the member is homogeneous (same everywhere) and isotropic (no directionality); and,
- if the member experiences uniform deformation (member remains straight and the cross section remains planar) during loading,

then the stress across a cross section (sufficiently far away from the ends of the member) is given exactly by its average value; that is,

$$\sigma_x = (\sigma_x)_{ave} = \frac{P}{A} = \text{constant across the cross section}$$

### Sign conventions

- If  $P > 0$  (member in tension), then  $(\sigma_x)_{ave} > 0$  (stress pointing outward on face of cut)
- If  $P < 0$  (member in compression), then  $(\sigma_x)_{ave} < 0$  (stress pointing inward on face of cut)

### Dimensions and units

Stress is a measure of the distribution of force over an area; thus, stress has dimensions of force/area. The SI units of stress are pascals, Pa (1 Pa = 1 newton per square meter), or alternately, in MPa ( $10^6$  Pa) or GPa ( $10^9$  Pa), and the British units are pounds per square inch (psi), or alternately in ksi ( $10^3$  psi).

b) Extensional/compressive strains and Poisson's ratio

A unit-axial loading acts along the x-axis on a body having initial  $xyz$  dimensions of  $L_0$ ,  $h_0$  and  $b_0$ , respectively. As a result of the loading, the body stretches in the x direction and contracts in the y and z directions, to produce new dimensions of  $L$ ,  $h$  and  $b$ , as shown in the figure below.

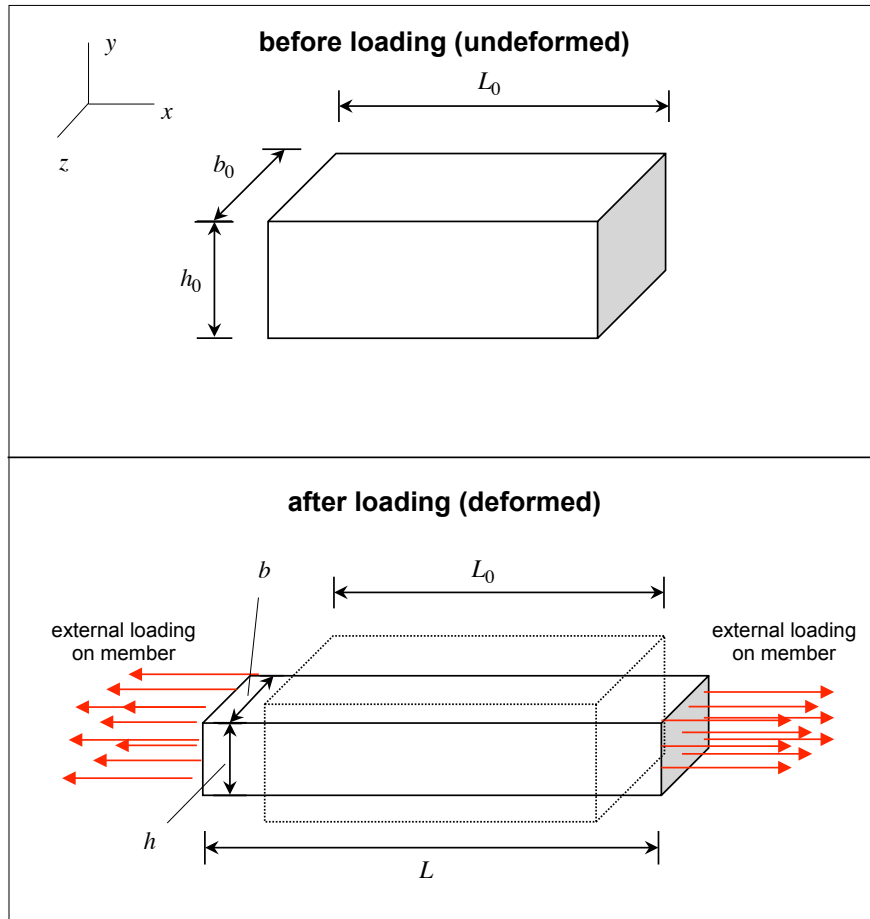

For this, we have the following definitions of strain components:

$$\epsilon_x = \text{strain in } x \text{ (axial) direction} = \frac{L - L_0}{L_0} = \frac{\Delta L}{L_0} \quad (\text{elongation in } x\text{-direction})$$

$$\epsilon_y = \text{strain in } y \text{ direction} = \frac{h - h_0}{h_0} = \frac{\Delta h}{h_0} \quad (\text{contraction in } y\text{-direction})$$

$$\epsilon_z = \text{strain in } z \text{ direction} = \frac{b - b_0}{b_0} = \frac{\Delta b}{b_0} \quad (\text{contraction in } z\text{-direction})$$

Note that the above strains are given by the ratio of the change in a dimension of the member ( $\Delta L$ ,  $\Delta h$  or  $\Delta b$ ) to the original dimension ( $L_0$ ,  $h_0$  or  $b_0$ , respectively). These definitions are known as “engineering strains”.

Poisson’s ratio

Elongation (contraction) in the axial direction due to an axial load produces a contraction (elongation) in the transverse directions. For many materials this transverse contraction (elongation) is linearly related to the elongation (contraction) in the axial direction and is independent of transverse direction. Based on this, we can write the relationships between the axial and transverse strains as:

$$\epsilon_y = \epsilon_z = -\nu\epsilon_x$$

where  $\nu$  is known as the “Poisson’s ratio” for the material. From this equation we see that Poisson’s ratio is a dimensionless quantity.

Note that the Poisson’s ratio for a material is related to the volumetric change in the material as a result of the loading. To see this, consider a cubic section of material with initial dimensions of  $L \times L \times L$ , giving a initial material volume of  $V = L^3$ . The material is given a loading along the x-axis as shown below.

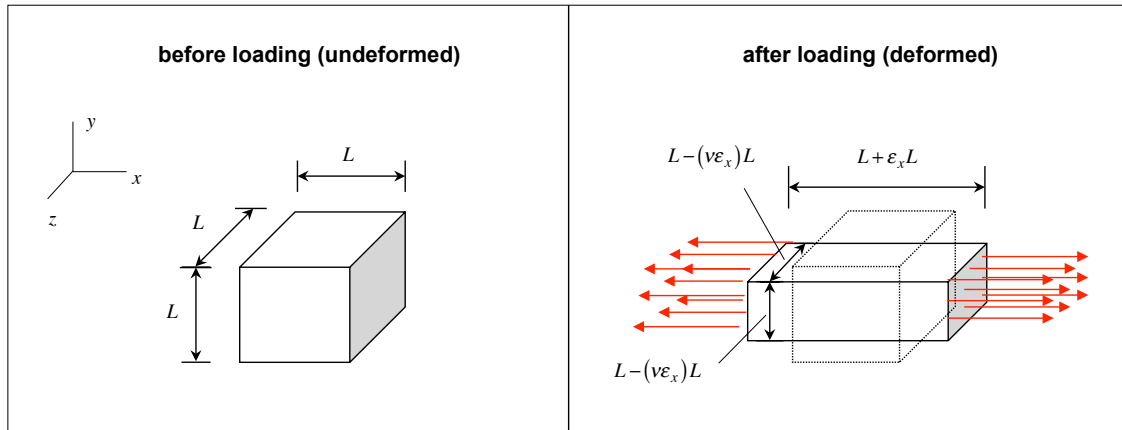

As a result of this loading, the new dimensions are  $(L + \epsilon_x L) \times (L - \nu \epsilon_x L) \times (L - \nu \epsilon_x L)$  giving a change in volume of:

$$\begin{aligned} \Delta V &= L^3 - L^3(1 + \epsilon_x)(1 - \nu \epsilon_x)^2 \\ &= L^3(1 - 2\nu)\epsilon_x + \text{nonlinear terms in } \epsilon_x \\ &\approx L^3(1 - 2\nu)\epsilon_x \quad ; \text{ for small } \epsilon_x \end{aligned}$$

Therefore:

$$\frac{\Delta V}{V} = (1 - 2\nu)\epsilon_x$$

Questions related to Poisson's ratio:

- a) What range of values for Poisson's ratio should be expected?
- b) What significance is there for a Poisson's ratio value of  $\nu = 0.5$ ?
- c) What significance is there for a negative Poisson's ratio (such a material is known as "auxetic")?

| Material ⇄      | Poisson's ratio ⇄ |
|-----------------|-------------------|
| rubber          | 0.4999 [5]        |
| gold            | 0.42–0.44         |
| saturated clay  | 0.40–0.49         |
| magnesium       | 0.252–0.289       |
| titanium        | 0.265–0.34        |
| copper          | 0.33              |
| aluminium-alloy | 0.32              |
| clay            | 0.30–0.45         |
| stainless steel | 0.30–0.31         |
| steel           | 0.27–0.30         |
| cast iron       | 0.21–0.26         |
| sand            | 0.20–0.45         |
| concrete        | 0.1–0.2           |
| glass           | 0.18–0.3          |
| foam            | 0.10–0.50         |
| cork            | 0.0               |

*schematic of auxetic material*

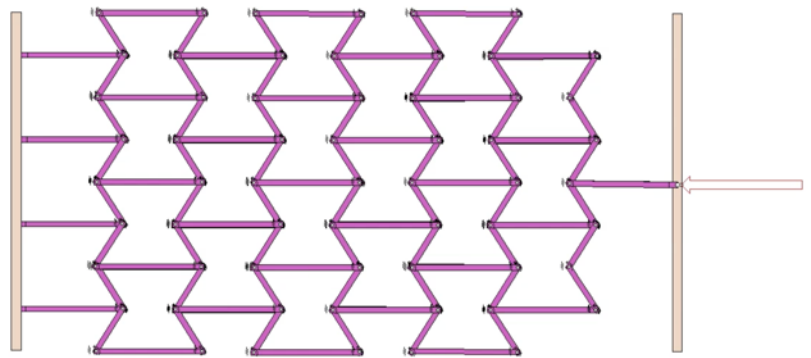

### Sign conventions

- If  $P > 0$ , then  $L > L_0$  (member experiences longitudinal extension), and:
  - $\epsilon_x > 0$
  - For most engineering materials,  $b < b_0 \Rightarrow \epsilon_y < 0$  and  
 $h < h_0 \Rightarrow \epsilon_z < 0$  (contraction in the y and z directions)
- If  $P < 0$ , then  $L < L_0$  (member experiences longitudinal contraction)
  - $\epsilon_x < 0$
  - For most engineering materials,  $b > b_0 \Rightarrow \epsilon_y > 0$  and  
 $h > h_0 \Rightarrow \epsilon_z > 0$  (expansion in the y and z directions)

### Dimensions

Strains are a measure of a change in length dimension divided by a length dimension. Therefore, strain is a *dimensionless* quantity. Often, however, strain is given in terms of either SI or British units as “mm/mm” or “inch/inch”, respectively, although the number itself has no dimensions associated with it.

c) Mechanical properties of materials

Consider the uni-axial loading  $P$  of test specimen shown below:

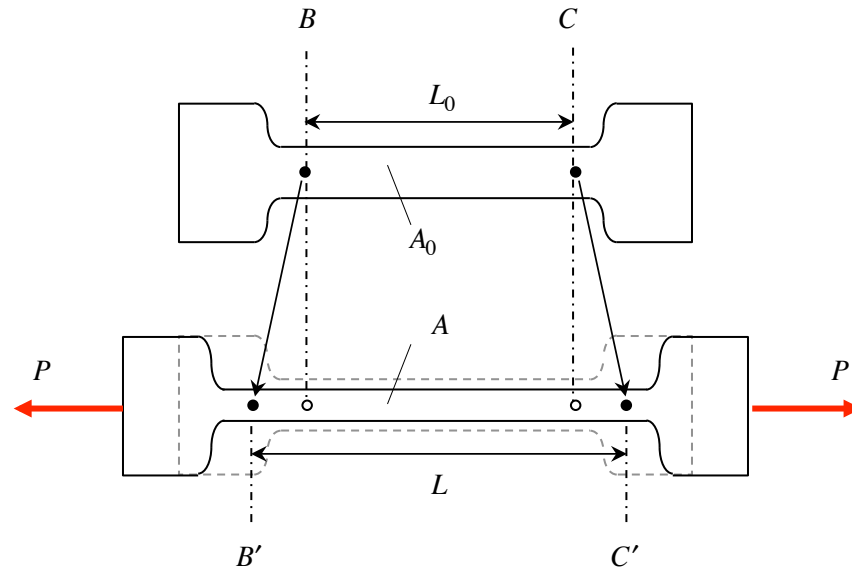

As a result of the loading, the narrow section in the middle increases in length from  $L_0$  to  $L$ , and decreases in cross-sectional area from  $A_0$  to  $A$ .

During a uni-axial test, both the load  $P$  and the change in length of the middle section  $\Delta L$  are monitored and recorded. From this, the stress  $\sigma$  and  $\epsilon$  are calculated using<sup>1</sup>:

$$\sigma = \frac{P}{A_0}$$

$$\epsilon = \frac{\Delta L}{L_0}$$

where  $\Delta L = L - L_0$ . The calculated stress and strain are then plotted on a set of axes to produce the stress-strain curve for the material of the test specimen. Characterizations of stress-strain curves for a few materials are shown in the following (figures provided courtesy of Professor Thomas Siegmund, Purdue University).

---

<sup>1</sup> Note that the stress  $\sigma$  here is found by dividing the resultant force  $P$  by the undeformed cross-sectional area  $A_0$ , rather than by the deformed cross-sectional  $A$ . This is known as the “engineering stress”. The strain  $\epsilon$  found here is the “engineering strain”, as defined earlier.



steel

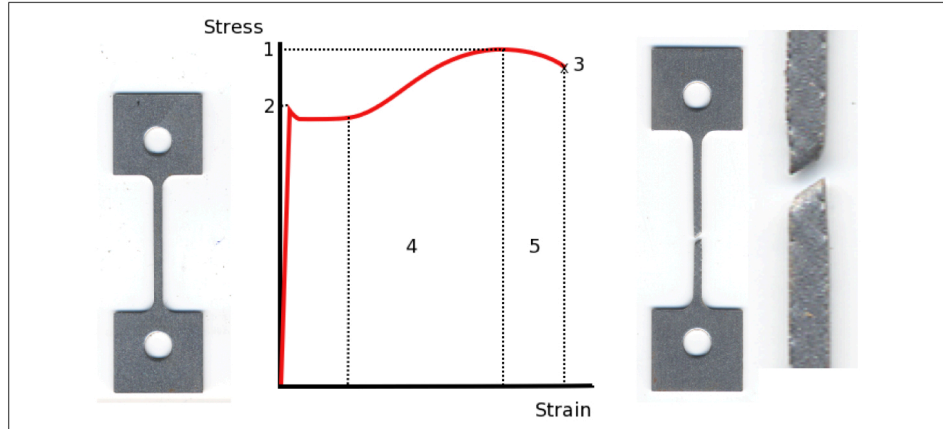

aluminum

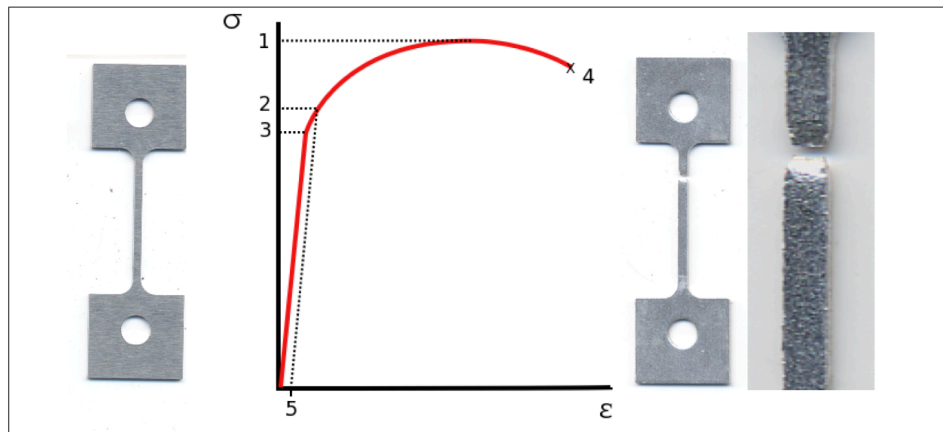

nylon

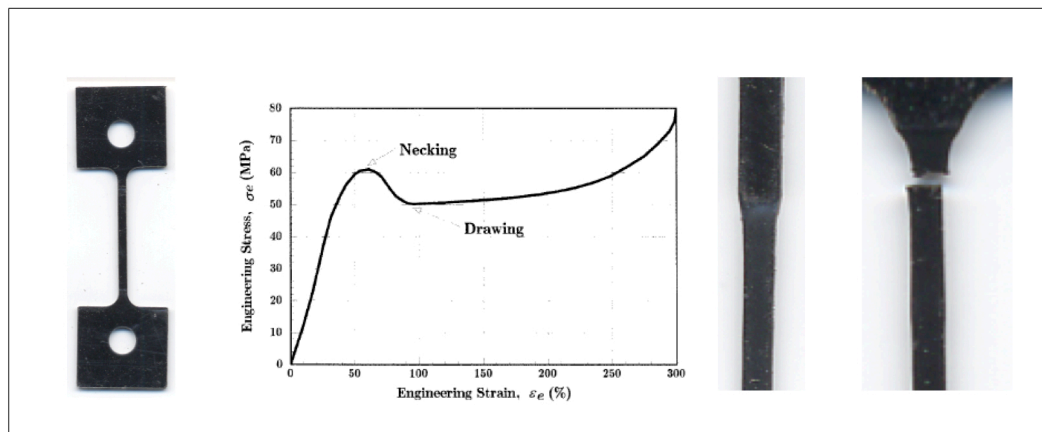

The generic shape of the experimentally-determined relationship between stress and strain for *structural steel* is shown in following figure. In the following, we will discuss the material behavior of different regions of this plot as demarcated in terms of the level of axial strain.

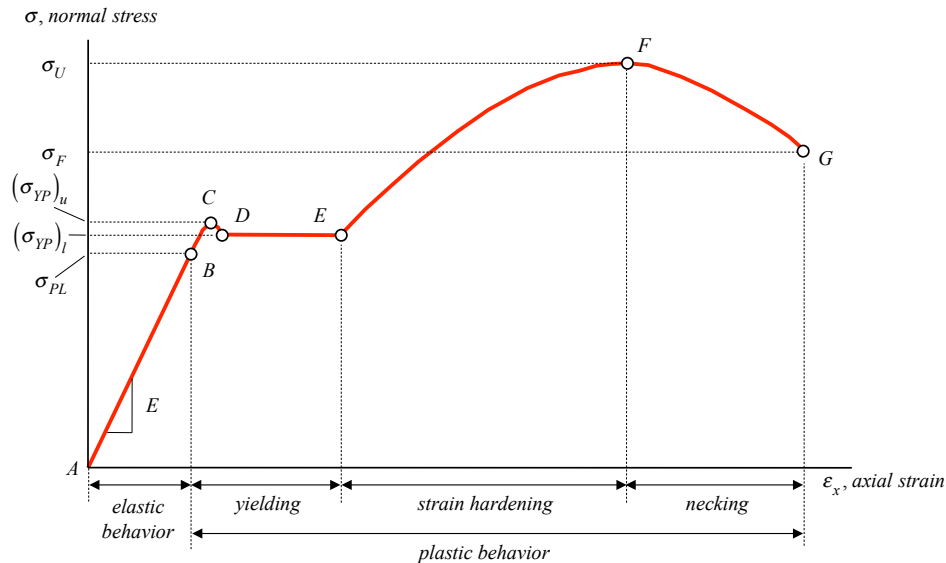

- *Elastic region, A-B.* For low levels of strain, there is a nearly linear relationship between stress and strain. The slope of the stress-strain curve is typically denoted as  $E$  (Young's modulus for the material). For  $\sigma > \sigma_{PL}$  (where  $\sigma_{PL}$  is known as the “proportional limit”, the slope decreases with increased strain (the material “softens” in its stiffness). Although the material behavior is still elastic, stress is no longer proportional to stress. In the elastic region, the unloading curve moves back along the loading curve shown.
- *Yielding region, C-E.* With a continued increase in strain, the material moves into a region where it behaves plastically. Between C and D on the above curve, the material deforms with a negative stress-strain slope, and between D and E, the material strain increases without any increase in stress (“perfectly plastic” behavior). The stress level corresponding to D,  $(\sigma_{YP})_l$ , is known as the “lower yield point”, or simply the “yield point”,  $\sigma_{YP}$ . In the yielding region, an unloading curve will not retrace the loading curve shown. Reducing the axial load in the member to zero will result in a permanent offset in the specimen's length.
- *Strain hardening region, E-F.* Between E and F, the material experiences strain hardening (decreased slope of stress-strain curve) with increased applied load. The stress at F,  $\sigma_U$ , is known as the “ultimate stress” (or, “ultimate strength”).
- *Necking region, F-G.* For strains above F, the material “necks down” resulting in significant reduction in the cross sectional area of the specimen. At G, fracture (or breaking) occurs. The stress level at G,  $\sigma_F$ , is known as the fracture stress.

The generic shape of the experimentally-determined relationship between stress and strain for aluminum is shown in following figure.

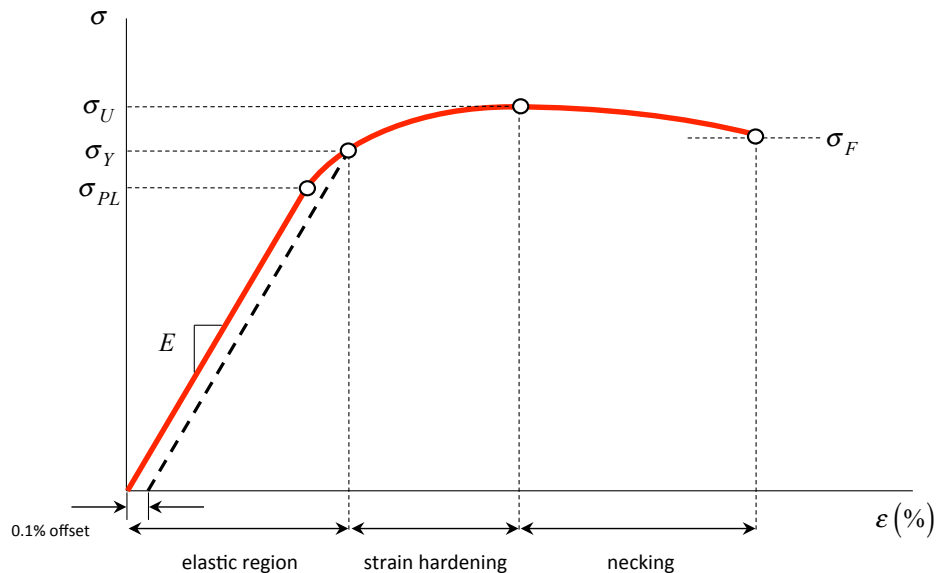

Comparing this relationship to that of structural steel we see that:

- Aluminum has a clear proportional limit (PL) where the stress is linearly proportional to strain.
- Young's modulus ( $E$ ): The slope of the stress-strain curve when  $\sigma < \sigma_{PL}$ .
- The yield point is not clearly defined and blends in with the non-linear elastic region. A perfectly plastic region is not observed.
- Offset yield stress ( $\sigma_Y$ ) is defined by choosing a 0.1% strain offset and drawing a straight line with slope =  $E$ , as shown above.
- The strain hardening region: Strain hardening occurs as in steel and results in an increasing stress level to a maximum value of ( $\sigma_U$ ) called the ultimate stress of the material.
- Necking: As the loading is increased further, the dislocations stretch across many grains and the material begins to neck and the engineering strain decreases.
- Failure: After sufficient necking, the material ruptures. The stress level here is the failure stress ( $\sigma_F$ ).

### Design Properties of materials

From the design viewpoint the most significant stress-strain properties can be categorized under these headings:

- *Strength of a material:* Is a measure of stress level that can be sustained by the material. Refers either to its yield stress ( $\sigma_{YP}$ ) or its ultimate stress ( $\sigma_U$ ) or its failure stress ( $\sigma_F$ ).
- *Stiffness of a material:* Is a measure of how it resists deformation given an applied load. Refers to its Young's modulus (E).
- *Ductility of a material:* Is a measure of the extent of (plastic) strain permitted by the material before failure.
- *Toughness of a material:* measures its ability to absorb energy before failure. Refers to the area under the stress-strain curve in the plastic region.

Provided below is a table of properties for a select group of materials.

| Material                   | Young's modulus, E |     | Poisson's ratio, $\nu$ | Yield strength, $\sigma_{YP}$ |     | Ultimate strength, $\sigma_U$ |     |
|----------------------------|--------------------|-----|------------------------|-------------------------------|-----|-------------------------------|-----|
|                            | $10^3$ ksi         | GPa |                        | $10^3$ ksi                    | GPa | $10^3$ ksi                    | GPa |
| Aluminum alloy 2014-T6     | 10.6               | 73  | 0.33                   | 60                            | 410 | 70                            | 480 |
| Aluminum alloy 6061-T6     | 10.0               | 70  | 0.33                   | 40                            | 275 | 45                            | 310 |
| Brass, cold-rolled         | 15                 | 100 | 0.34                   | 60                            | 410 | 75                            | 520 |
| Brass, annealed            | 15                 | 100 | 0.34                   | 15                            | 100 | 40                            | 275 |
| Cast iron, gray            | 10                 | 70  | 0.22                   | -                             | -   | 25                            | 170 |
| Steel, ASTM-A36 structural | 29                 | 200 | 0.29                   | 36                            | 250 | 58                            | 400 |
| Steel, AISI 302 stainless  | 29                 | 195 | 0.30                   | 75                            | 520 | 125                           | 860 |
| Titanium, alloy            | 16.5               | 115 | 0.33                   | 120                           | 830 | 130                           | 900 |
| Wood, Douglas Fir          | 1.75               | 12  | -                      | -                             | -   | 7.5                           | 60  |
| Wood, Southern Pine        | 1.75               | 12  | -                      | -                             | -   | 8.5                           | 60  |

### Example 2.2

For small loads  $P$ , the rotation of the rigid beam  $AF$  is controlled by the stretching of rod  $AB$ . For larger loads, the beam comes into contact with the top of column  $DE$ , and further resistance to rotation is shared by the rod and the column. Assume that the clockwise angle  $\theta$  through which beam  $AF$  rotates is small enough to assume that points on the beam essentially move vertically. The cross-sectional areas of members (1) and (2) are  $A_1$  and  $A_2$ , respectively, and the materials of members (1) and (2) have Young's modulus of  $E_1$  and  $E_2$ , respectively.

- A load  $P$  is applied that is just sufficient to close the  $\Delta$  gap between the beam and the column. What is the strain  $\epsilon_1$  in rod  $AB$  for this value of  $P$ ?
- If the load  $P$  in a) is doubled, what is the corresponding strain  $\epsilon_2$  in column  $DE$ ?

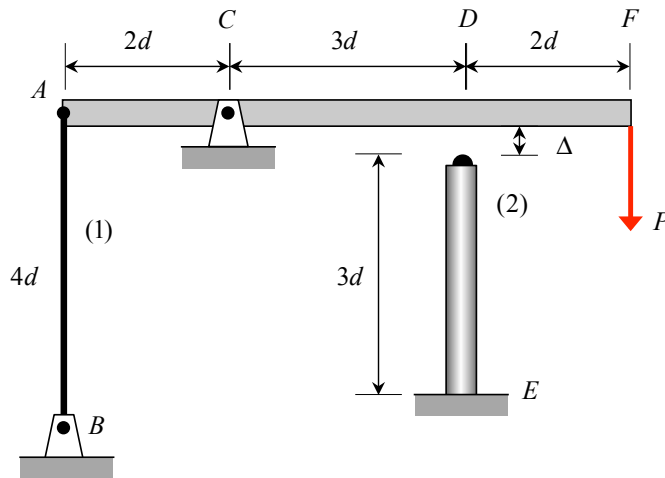

### Example 2.4

A cylindrical rod having an initial diameter of  $d_0$  and initial length  $L_0$  is made of 6061-T6 aluminum alloy. When a tensile load  $P$  is applied to the rod, its diameter is decreased by  $\Delta d$ .

- Determine the magnitude of the load  $P$ .
- Determine the elongation of the rod over the length of the rod.

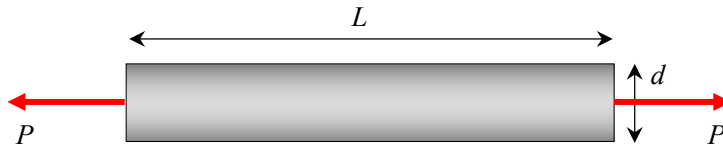

### Example 2.6

The tapered rod has a radius of  $r=(2-x/6)$  in. and is subjected to the distributed loading of  $p = (60+40x)$  lb/in. Determine the average normal stress at the center of the rod, B.

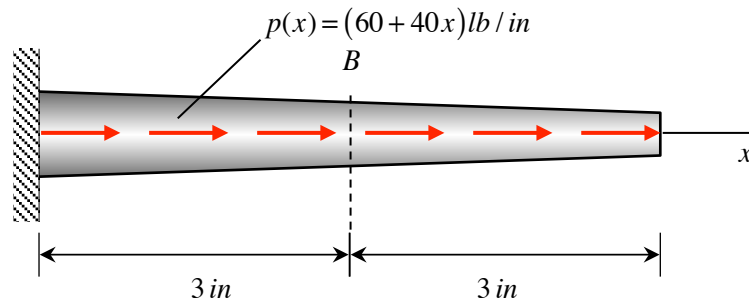

$$r(x) = \text{cross-section radius} = \left(2 - \frac{x}{6}\right) \text{ in}$$

### Solution

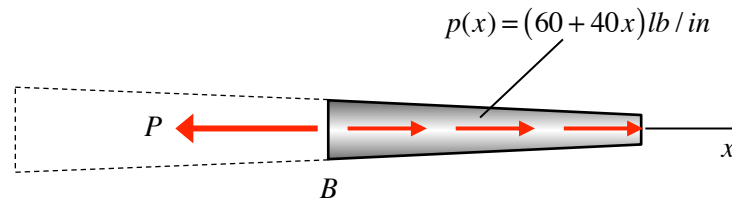

$$\sum F_x = -P + \int_3^6 p(x) dx = 0 \Rightarrow P = \int_3^6 (60 + 40x) dx = 720 \text{ lb}$$

$$A = \pi \left(2 - \frac{3}{6}\right)^2 = 7.07 \text{ in}^2$$

$$\sigma_{ave} = \frac{P}{A} = \frac{720}{7.07} = 102 \text{ psi}$$

### Example 2.7

The three-segment axially-loaded member shown below is made up of a tubular segment (1) with an outer diameter of  $d$  and inner diameter of  $0.75d$ , a solid segment (2) of outer diameter of  $d$  and another solid segment (3) of outer diameter of  $0.75d$ . A set of axial loads are applied at C, D and H. Determine the axial stresses in the three segments.

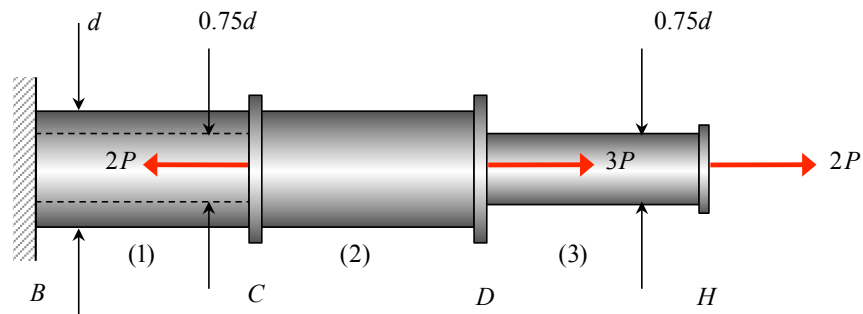



***Additional notes:***