

October 6, 2021

INSTRUCTIONS

Begin each problem in the space provided. If additional space is required, use the paper provided to you.

Work appearing on the backside of any exam page may NOT be graded.

In order for you to obtain maximum credit for a problem, the solution must be clearly presented and in accordance with the following guidelines.

- Coordinate systems used must be clearly identified.
- Wherever appropriate, free body diagrams must be drawn. These should be drawn separately from the given figures.
- Units must be clearly stated as part of the answer when numerical answers are presented.
- Vectors must be clearly identified with proper vector notation.

If the solution does not follow a logical thought process, it will be assumed to be in error.

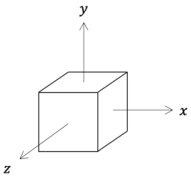
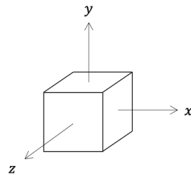
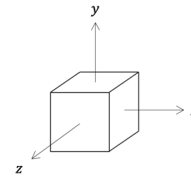
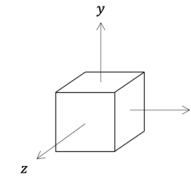
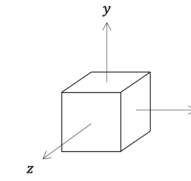
<ul style="list-style-type: none"> • Draw the machine component's critical cross-section. • Identify and label the potential locations for the critical element(s) (e.g., top, bottom, right, left, and center) 						
Potential location of critical element						
Internal load	Axial					
	Torsion					
	Transverse shear					
	Bending					
Stress element						

PROBLEM No. 1 (25 points)

Problem 1 consists of 10 questions. Each question is worth 2.5 points.

- (a) When using oversized (positively toleranced) keys, the engineer needs to be concerned with backlash when torque-loads cycle between -10 N-m to 50 N-m.

- True
 False

In a few words, justify your answer.

- (b) Finish this sentence.

A Marin factor $k_b = .987$ indicates your part is ...

- (c) The table below summarizes safety factors for three different designs.

	Design A	Design B	Design C
Keyseat	3.1	3.5	3.92
Key	1.8	4.1	3.90
Keyway	2.8	3.2	3.91

Which of the designs is most appropriate?

- Design A
 Design B
 Design C

In a few words, justify your answer.

(d) On the idealized $S-N$ Diagram for Steels, the Low Cycle - Finite Life region is defined by what two points?

(e) For which of the following loads is $k_c = 1$?

- Axial
- Transverse shear
- Bending
- Torsion
- Combined

(f) A part has a stress raiser with a notch radius of 5 mm. The part is made of a material with $S_{ut} = 700$ MPa and is subjected to a completely reversed torque.

Determine the notch sensitivity.

(g) Which, when designed correctly, provides a better and greater transfer of torsional loads between components while accommodating large axial motion between shaft and mating component?

- Retaining rings
- Setscrews
- Shear Pins
- Splines
- Keys
- Interference fit

In a few words, justify your answer.

(h) When designing shafts with bearings and overhung gear(s), the designer should minimize what two shaft centerline factors?

1.

2.

(i) In class, we have primarily focused on the Goodman criterion due to its simplicity and its conservative design prediction.

The fluctuating stress diagram for the Goodman criterion is shown below.

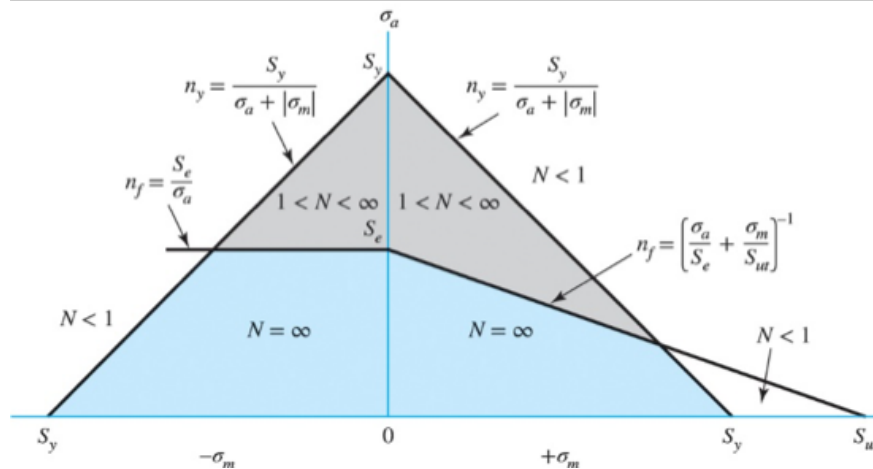

In the space provided, draw and label the fluctuating stress diagram using the Goodman criterion for pure shear.

(j) Provide what you believe is the most important reason why some products/components are designed with finite life.

PROBLEM No. 2 (10 points)

The right-angle cantilevered bracket shown is fixed to a wall at O .

The bracket is subjected to two loads at location B .

- A force $P_z = 1000$ N that acts in the $-z$ -direction.
- A torque $T_y = 300$ N-m that acts about the $+y$ -direction.

The bracket has a circular cross-section with diameter $d = 0.035$ m.

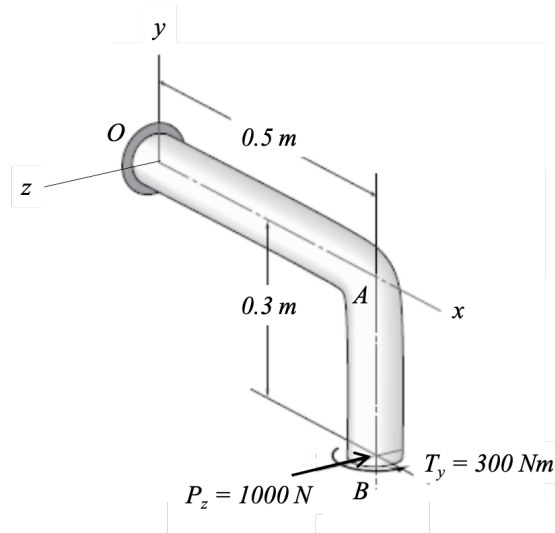

Determine the following.

(a) The internal loads acting in segment AB are (select all that apply):

- Axial compression
- Axial tension
- Torsion
- Bending
- Transverse shear

(b) The internal loads acting in segment OA are (select all that apply):

- Axial compression
- Axial tension
- Torsion
- Bending
- Transverse shear

(c) Identify the critical cross-section(s) of the bracket. Justify your choice(s).

PROBLEM No. 2 (Continued)

PROBLEM No. 3 (20 points)

A hollow shaft is supported by bearings at locations A and B .

The shaft is loaded with a constant torque (T), causing the shaft to rotate at a constant 2000 rpm. No other loads are applied to the rotating shaft.

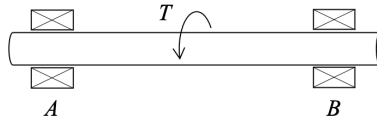

The shaft has outer diameter $D = 25$ mm, inner diameter $d = 19$ mm, cross-sectional area $A = 207$ mm², $I = 12780$ mm⁴, and $J = 25560$ mm⁴.

Determine the following.

(a) Identify the critical element(s) of the rotating shaft.

(b) Draw the stress state for the critical element(s) identified in part (a). Use the stress element provided below.

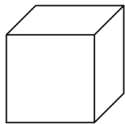

(c) Draw the Mohr's circle for the stress state drawn in part (b). Label principal stresses σ_A and σ_B .

PROBLEM No. 3 (Continued)

- (d) The power, in kW, that can be transmitted through the shaft if the shaft is made of AISI 1040 HR steel with $S_y = 290$ MPa.
- Use the Maximum Shear Stress (MSS) Theory with a factor of safety of $n = 2$.
 - Plot and label the failure envelope for the MSS theory on the axes given. Show the location of the stress state for the loading given.
- (e) If you were to repeat part (d) with the Distortion Energy (DE) Theory, do you expect the power transmitted to be higher or lower? In a few words, justify your answer.

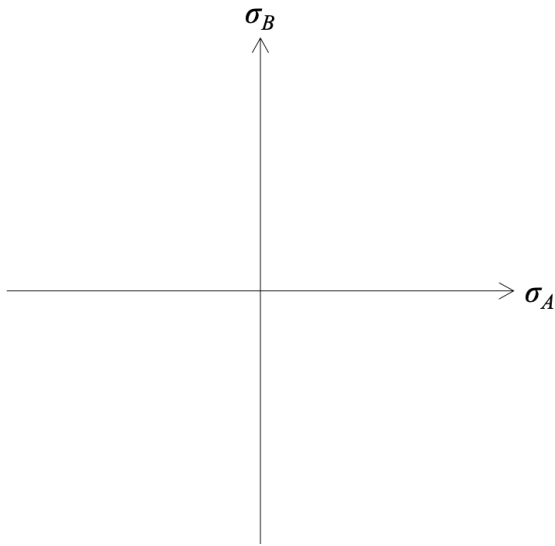

PROBLEM No. 3 (Continued)

PROBLEM No. 4 (20 points)

In class, we have described rotating bending fatigue tests used to determine the endurance limit of a test specimen.

Another type of test specimen used in fatigue tests is a double-edge-notched tension (DENT) specimen. These test specimens have rectangular cross-sections and are subjected to axial loads.

A particular DENT specimen is made of AISI 1095 HR steel ($S_{ut} = 120$ kpsi). This DENT specimen was tested at room temperature, and the 50% reliability endurance limit was measured to be $S_e = 50$ kpsi.

Determine the following.

- Draw and label the S - N curve for the DENT specimen described above on the axes provided.
- For the DENT specimen described above, determine the fatigue strength for a life of 10^5 cycles.
- The endurance limit of DENT specimen described above if the test was repeated at 800°F and a 99.99% reliability is desired.

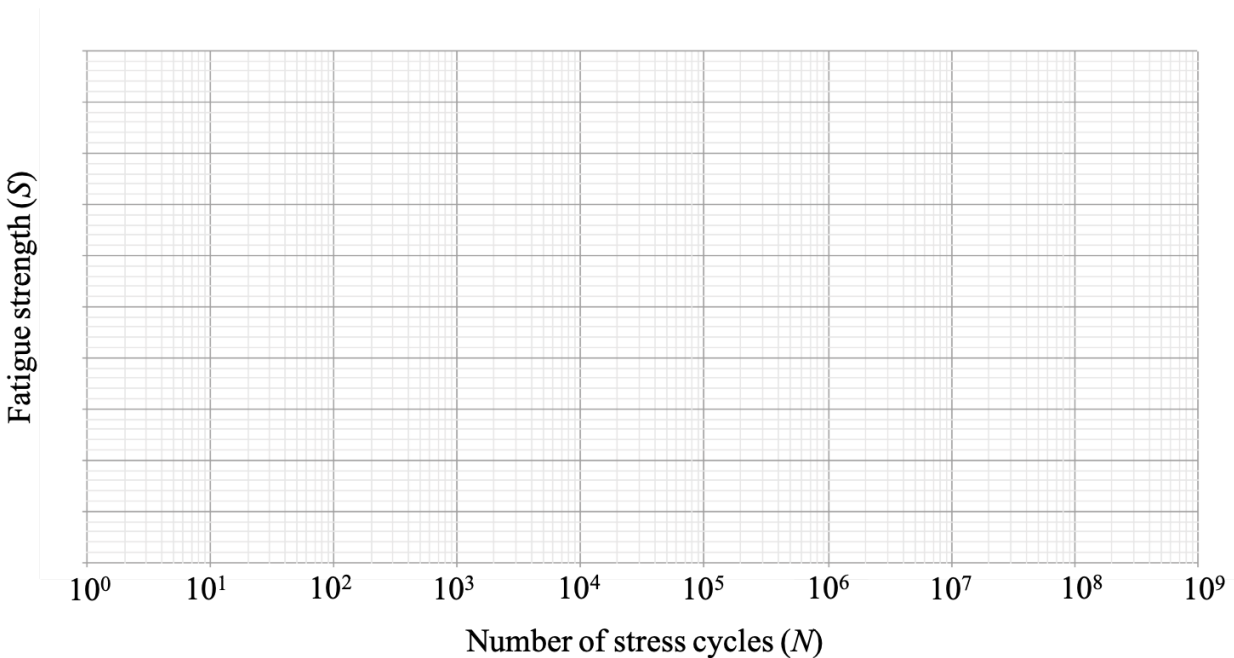

PROBLEM No. 4 (Continued)

PROBLEM No. 5 (25 points)

A tension member in a machine is filleted as shown below.

The bar is machined and its dimensions are $D = 2.2$ in, $d = 2$ in, and $r = 0.1$ in. The member is 0.5 in thick.

The material is AISI 1018 CD steel and is fully notch sensitive ($q = 1$) with $S_{ut} = 64$ kpsi, $S_y = 54$ kpsi, and a fully corrected endurance limit of $S_e = 28$ kpsi.

The tensile load F fluctuates from a minimum of 200 lbf to a maximum of 800 lbf.

A manufacturing defect caused the tensile load to be applied eccentrically, resulting in a fluctuating bending moment as well. The bending moment M fluctuates between 300 lbf-in and 1200 lbf-in.

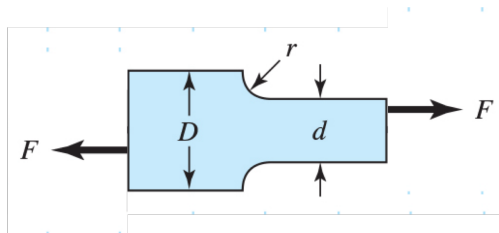

Determine the following.

- (a) Locate the stress state (σ'_m, σ'_a) on the fluctuating stress diagram shown.
- (b) The factor of safety for fatigue based on infinite life, using the Goodman criterion. If infinite life is not predicted, estimate the number of cycles until failure.
- (c) Check for first-cycle yielding.

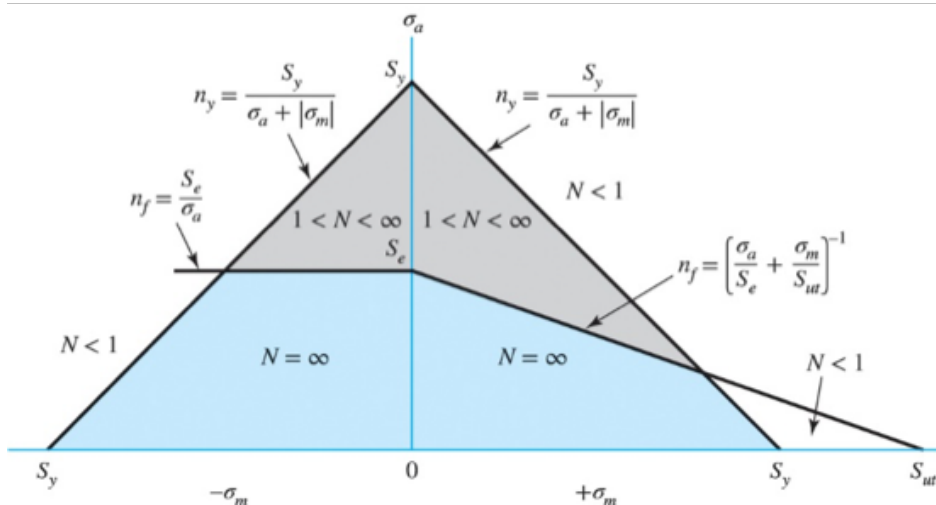

PROBLEM No. 5 (Continued)

PROBLEM No. 5 (Continued)